

APPENDIX B

Filtering device
UFO-A-N and UFO-A-N/R**EN**

The appendix is valid for the following device models:

Catalog No.	Product name
805U20	UFO-A-5000-N
805U21	UFO-A-10000-N
805U22	UFO-A-15000-N
805U23	UFO-A-20000-N
805U24	UFO-A-5000-N/R
805U25	UFO-A-10000-N/R
805U26	UFO-A-15000-N/R
805U27	UFO-A-20000-N/R

Sequencer

E1T 4÷16 Output Channels



Use and Maintenance Instructions

Description	3
Electrical Specifications	4
Dimensions and Constrains.....	5
Warning symbols used in this manual	6
Installation regulations and warnings	6
Electrical wirings	8
Terminals Table	9
Recommended cable cross-section	10
Fuse Table & replacing	10
Jumper Configuration for Power Supply Input	11
Jumper Configuration for Output Voltage	11
Display and pushbuttons	12
Accessing the programming menu	12
List of Parameters	13
Description of the operations	14
Operating Modes	15
Other functions	15
Hour Counters	16
Inputs & Outputs	17
Alarms	18
Troubleshooting	19
Maintenance	20
Disposal	20
Warranty	20
Warranty Exclusions	20

Description

The E1T control unit is an electronic device designed to drive pneumatic cleaning of industrial dust collector systems.

The construction technology of the control unit allows to connect up to 16 solenoid valves.

The control unit is equipped with a powerful microcontroller that, thanks to an innovative software, makes the instrument easy to use even by inexperienced users.

The control unit is equipped with a seven-segment display, through which the user can monitor the entire cleaning process and make the settings by means of a series of buttons placed on the front panel of the device.

Main features:

- 2 digital free-voltage contact inputs for remote control (Remote Enable & Fan Status);
- 2 Alarm relays (event programmable);
- 16 outputs for solenoid valve actuators;

Other features:

- 7 segment 3 digits 0,8" LED display;
- Power supply selectable in hardware for 115-230Vac 50/60Hz or 24Vac-24Vdc;
- Output voltage selectable in hardware and software for 24Vdc, 24Vac, 115Vac, 230Vac;
- Fully configurable cleaning cycle;
- Post cleaning function (PCC) when Fan is OFF, by detection on the "Fan Status" contact input;
- Total and partial hours counter for maintenance;
- Alarm for solenoid valve not operating;
- Alarm for maintenance of filter elements;
- Remote enabling of the Control unit by mean of "Remote Enable" contact input;
- Single solenoid actuator manual activation for system check;

Electrical Specifications

Power Supply Voltage		115Vac 50/60 Hz \pm 10 % 230Vac 50/60 Hz \pm 10 % 24Vac 50/60 Hz \pm 10 % (on request) 24Vdc \pm 10 % (on request)
Power consumption		28 VA @ max Load (on request: 50VA)
Protection fuse		1AT (115Vac - 230Vac models) 3AT (24Vac / 24Vdc models)
Operating Temperature		-10°C ÷ 55°C
Storage Temperature		-20°C ÷ 60°C
Environmental Humidity		0 ÷ 95% Relative (Non Condensing)
Solenoid valve opening Pulse Time		50msec ÷ 9,99sec
Pause Time between solenoid solenoids activations		1sec ÷ 999sec
Output Voltage For Solenoid solenoids		115Vac 50/60 Hz 230Vac 50/60 Hz 24Vac 50/60 Hz 24Vdc
Digital inputs (Not galvanically isolated free-voltage input)		1x FAN OFF detection 1x REMOTE Enable
Digital outputs (free-voltage contacts)		2x SPST FORM A Relay contact
Display		3 digit 0,8" 7 segments LED display
Casing		Base = ABS Transparent cover = Polycarbonate
Protection Degree from water and dust		IP65 DIN EN 60529
Shock Resistance		IK08 (EN62262).
Weight		2,1 Kg

Dimensions and Constrains

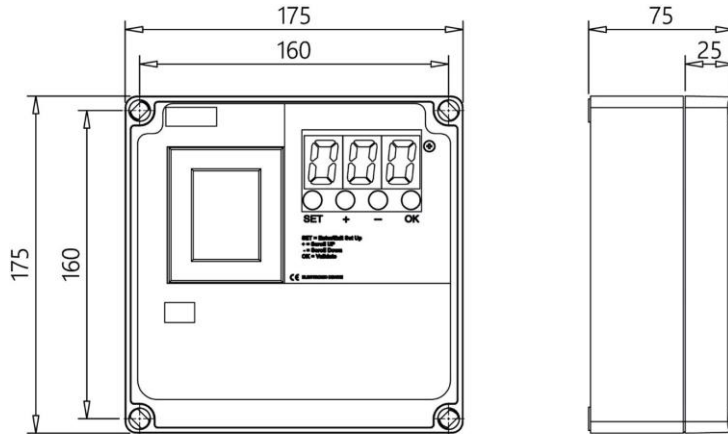

*4-8 Outputs Enclosure
 Dimensions in mm*

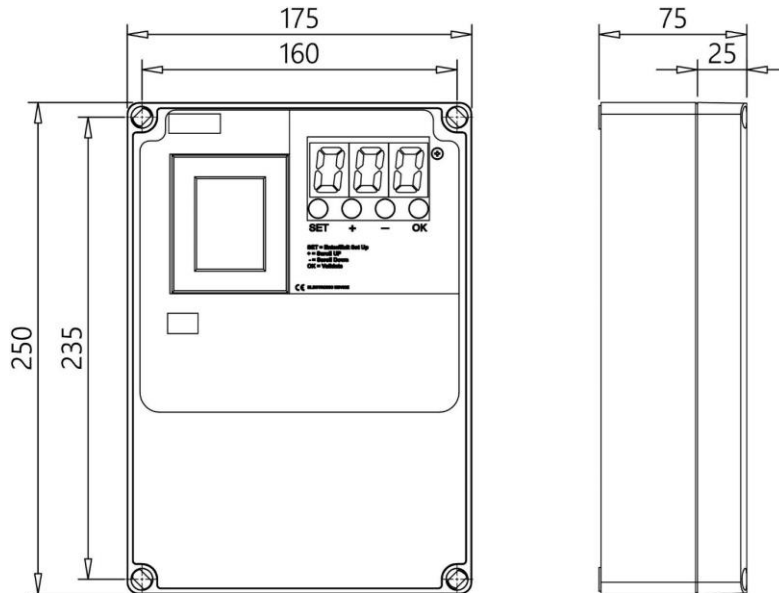

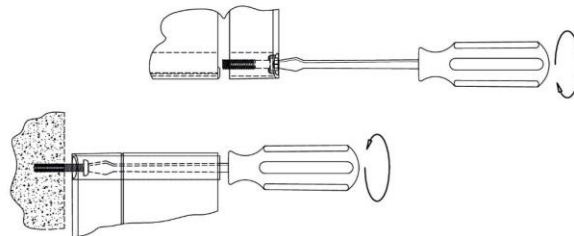

*12-16 Outputs Enclosure
 Dimensions in mm*









Warning symbols used in this manual

The safety-related indications are highlighted using the symbols:

	Attention - Danger	Warning - Generic
	Risk – Danger	Electric Current
	Dispose of in compliance with the electrical and electronic equipment Standard WEEE	

Installation regulations and warnings

<ul style="list-style-type: none"> Protect the equipment from direct exposure to sunlight. 	
<ul style="list-style-type: none"> Do not position the equipment near or directly in contact with sources of heat or electromagnetic fields. 	
<ul style="list-style-type: none"> Fix the Control Unit at a height of at least 60 cm from the ground floor and in a clearly visible place that is easily accessible. 	
<ul style="list-style-type: none"> Connect the Control Unit to a power supply line other than those used for operating motors or other high-power devices, which could generate network interference or instability. 	
<ul style="list-style-type: none"> The power supply must be protected by a 230Vac 30mA Residual Current Device RCD and a bipolar 230Vac 10A magnet circuit breaker, positioned in a place that is easily accessible. 	
<ul style="list-style-type: none"> Before intervening on the equipment to perform any operation, deactivate the magnet circuit breaker switch and check if the environment conditions are safe. 	
<ul style="list-style-type: none"> For electric operations, always remove voltage, wait 30 seconds for the internal capacitors to discharge before opening. At the end of the operations, close the equipment before powering up. Before intervening on the equipment to perform any operation, check the conditions of the atmosphere are safe. 	
<ul style="list-style-type: none"> The PE (ground terminal/Earth) wire must be Yellow/Green, and it must be the first to be connected. No other cables different than PE must be with its color. 	
<ul style="list-style-type: none"> The terminal block must not be the mechanical anchorage point of the wires. 	
<ul style="list-style-type: none"> Sealing of the cable glands is guaranteed by the compression of the rubber gasket that tightens on the outer diameter of the cable. 	
<ul style="list-style-type: none"> The size of cable and cable gland must ensure that power cord traction is not acting on the terminal. 	

<ul style="list-style-type: none"> Any use not described in this user instruction manual or incorrect use of the device may cause damage to the Control Unit or to the equipment connected to it. 	
<ul style="list-style-type: none"> Incorrect use or tampering with the equipment may cause injury. 	
<ul style="list-style-type: none"> The impermeability of the casing is guaranteed when the cover is closed. 	
<ul style="list-style-type: none"> Make sure that rigid or flexible ducts used for wiring, do not fill up with water or other liquids. 	
<ul style="list-style-type: none"> Switch OFF the power supply immediately if water is found in the casing. 	
<ul style="list-style-type: none"> Do not make unprotected holes in the container or holes that are protected by accessories with protection rating lower than that of the Control Unit. 	
<ul style="list-style-type: none"> If the Control Unit is used in ways not specified by the manufacturer, the protection provided by the device may be impaired. 	
<ul style="list-style-type: none"> No part with dangerous voltage is normally accessible. 	
<ul style="list-style-type: none"> The Control Unit does not release potentially toxic or harmful substances to the health and the environment. 	

	<p><u>IMPORTANT</u></p>
<p>Do not use the control unit if you have not read or do not understand this manual.</p>	

Electrical wirings

To connect the wires to the Control Unit, remove the lower front panel to access the terminal board, unscrewing the two screws.

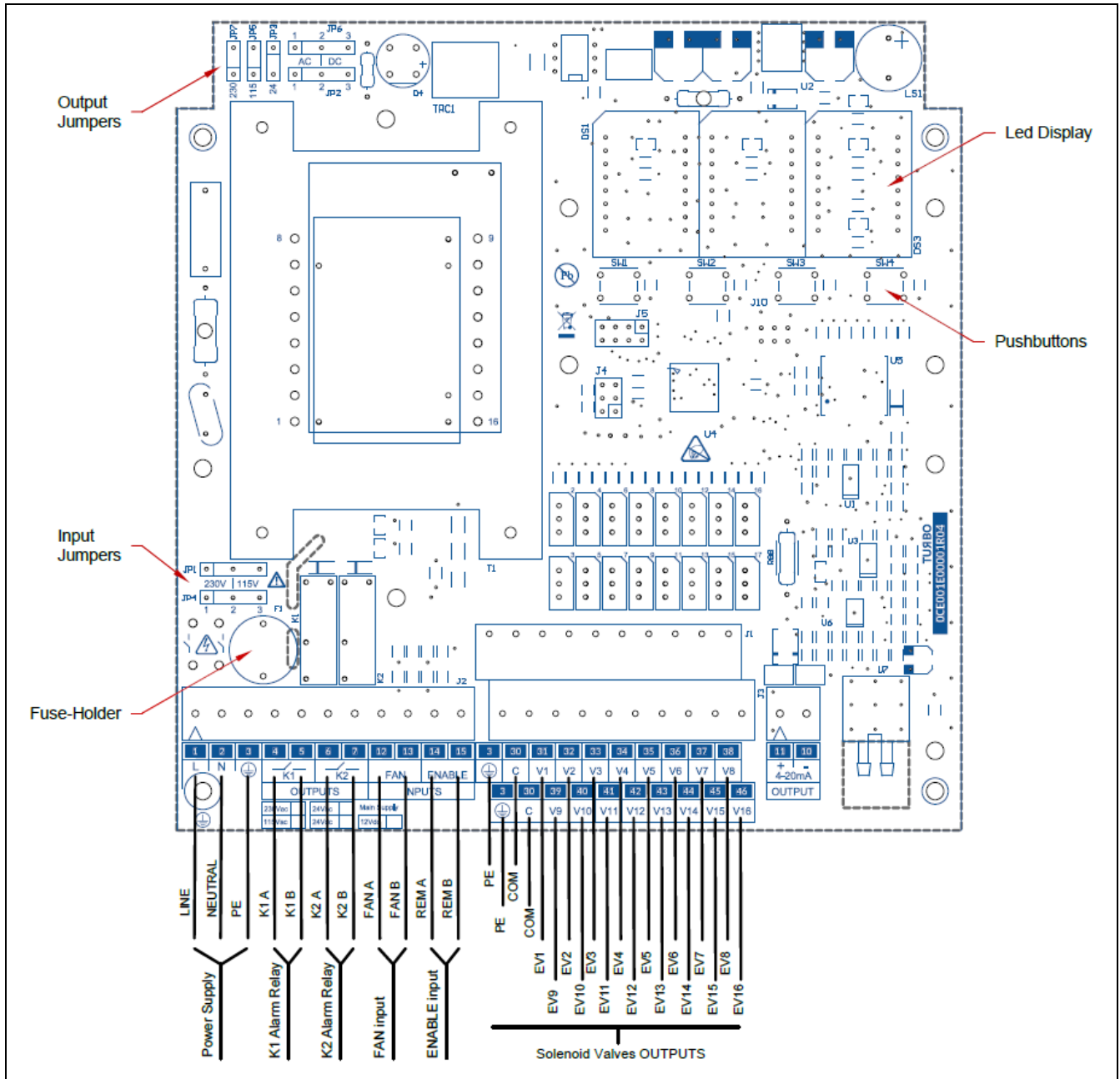

Note: If the Control Unit is a +24Vdc power-supplied model, please connect:

Terminal 1	=	+24Vdc IN
Terminal 2	=	0Vdc IN
Terminal 3	=	PE

Terminals Table

Ref.	Cat	Terminal	Marking	Description	
Main Power Supply	A	1	L	115-230Vac 50/60Hz ±10%	24Vac 50/60Hz ±10%
		2	N		24Vdc ±10%
	PE	3	PE	Protective ground terminal (Earth)	
Relay K1 Output ⁽¹⁾	B	4	1A	Contact type	1 Form A (1SPST NO)
				Ratings	250Vac/30Vdc 5A
		5	1B	Max switching voltage	400Vac
				Dielectric Strength	4000Vac (750Vac contacts)
		Expected life	10M mechanical, 100K electrical		
Relay K2 Output ⁽¹⁾	B	6	2A	Contact type	1 Form A (1SPST NO)
				Ratings	250Vac/30Vdc 5A
		7	2B	Max switching voltage	400Vac
				Dielectric Strength	4000Vac (750Vac contacts)
		Expected life	10M mechanical, 100K electrical		
Fan Status Input ⁽²⁾	C	12	FANA	Mode	Free contact (limited to 5mA@5V)
		13	FANB	Insulation	2KVac main transformer
Remote Enable Input ⁽²⁾	C	14	REMA	Mode	Free contact (limited to 5mA@5V)
		15	REMB	Insulation	2KVac main transformer
Ground	PE	3	PE	Protective ground terminal (Earth)	
Solenoid Valve Common	D	30	COM	Ratings	8A
				Max switching voltage	600VAC
Solenoid Valve Output	D	31	EV1	Ratings	4A
		32	EV2	Max switching voltage	600VAC
		33	EV3		
		34	EV4		
		35	EV5		
		36	EV6		
		37	EV7		
		38	EV8		
		39	EV9		
		40	EV10		
		41	EV11		
		42	EV12		
		43	EV13		
		44	EV14		
		45	EV15		
		46	EV16		

Note (1): Free-voltage SPST contacts.

Note (2): Free-voltage contacts powered by the main-board. DO NOT provide voltages at these terminals.



DANGER

Risk of electric shock

The input and output terminals, numbered 12 to 15 are safety extra low voltage (SELV) terminals and must only be connected to low voltage circuits.

Recommended cable cross-section

Cat	Cable Cross-section	Approvals	Notes
A	0,75 mm ²	IEC60227, IEC60245	No-Flame or flame-retardant cable
B	0,75 mm ²	IEC60227, IEC60245	No-Flame or flame-retardant cable
C	0,50 mm ²	IEC60227, IEC60245	No-Flame or flame-retardant cable
D	0,75 mm ²	IEC60227, IEC60245	No-Flame or flame-retardant cable
PE	0,75 mm ²	IEC60227, IEC60245	No-Flame or flame-retardant cable, Yellow/Green cable

Fuse Table & replacing

Voltage	Value
230 Vac	1AT 250V
115 Vac	1AT 250V
24Vac/dc	3AT 60V/250V



DANGER

Risk of electric shock

Before replacing the main Fuse on the board, you **MUST** remove the main power supply to avoid electrical shocks.

To replace the fuse:

- Remove the lower front panel;
- Unscrew the black fuse-holder cap;
- Remove the fuse cap with the fuse inside;
- Replace the fuse with a new one;
- Insert the fuse in the fuse cap;
- Insert the fuse cap into the fuse-holder;
- Screw the fuse-holder cap;
- Close the lower front panel;
- Power-on the Control Unit.

Jumper Configuration for Power Supply Input

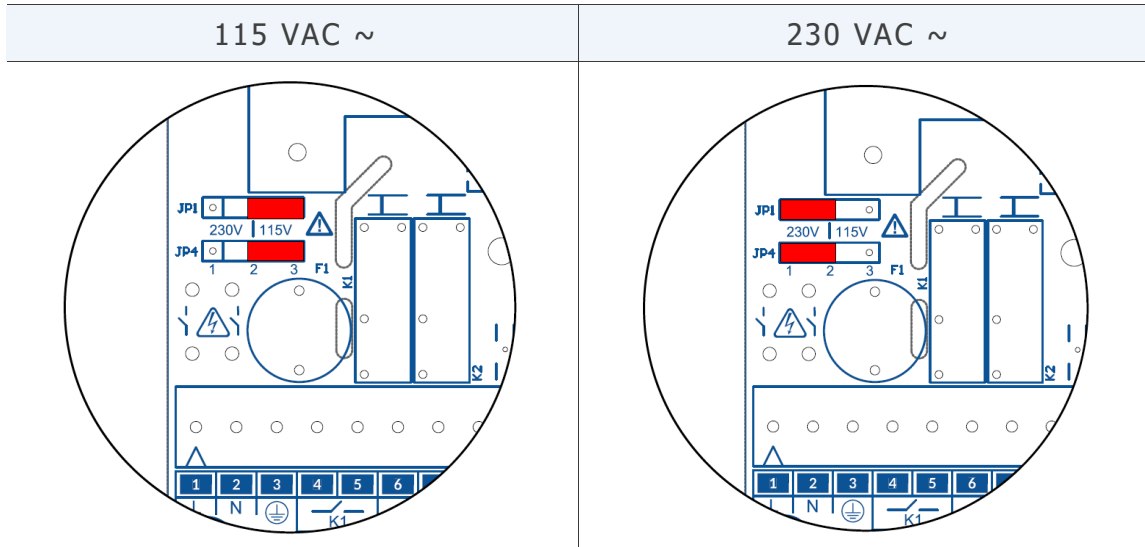

In the 24Vac and 24Vdc models JP1 and JP4 jumper are not used.

Jumper Configuration for Output Voltage

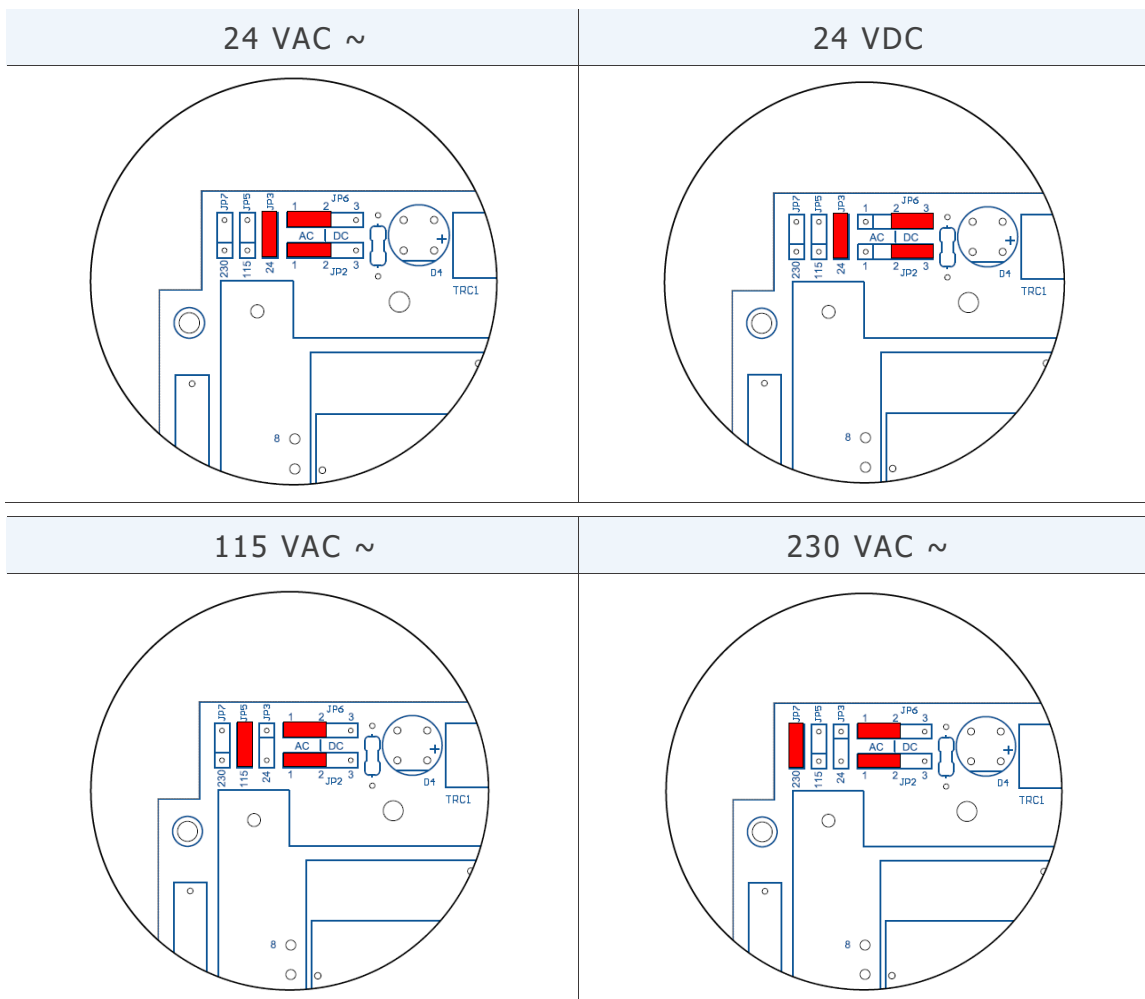

The output voltages 115Vac or 230Vac is not available in 24Vdc power input models.

Display and pushbuttons

A local user interface made of a large seven segment display and four pushbuttons is available on the Control Unit. The user interface shows the main functionalities and events during a cleaning process.

It is also useful to access to the programming parameters.

At power-on the Control Unit will show the software version mounted for few seconds and then it will be ready to be used.

The Pause Time countdown is the main information shown on display. It will be alternated with some other information like output pulsed and error codes.

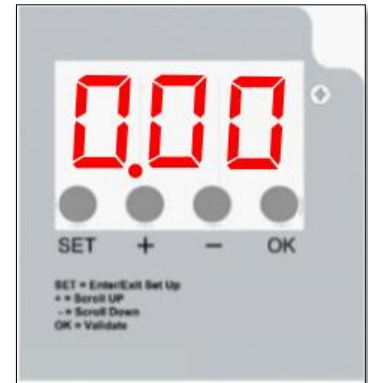

The pushbuttons enable the user to perform some operations:

(SET)	Enable the user to access or exit the programming mode.
	Activate a single solenoid during manual test with the related function F06, available in programming mode.
(OK)	Save parameter's value modified during programming mode.
	Reset alarms in main screen.
(+)	Increases the scroll of the parameters in programming mode.
	Increases the value of a selected parameter during programming.
	Displays the total hours counter since the first power-on.
(-)	Decreases the scroll of the parameters in programming mode.
	Decreases the value of a selected parameter during programming.
	Displays the partial hours counter for maintenance.

Accessing the programming menu

Press (SET) pushbutton to access the programming mode. The blinking message "F02" will appear to indicate the first parameter available.

Press (+) or (-) pushbuttons to move at the required parameter.

Press (OK) pushbutton to access the value of the selected parameter.

Press (+) or (-) pushbuttons to change the value of the parameter.

Press (OK) to save the parameter's value.

Press (SET) pushbutton to exit the programming menu and return to the main screen.

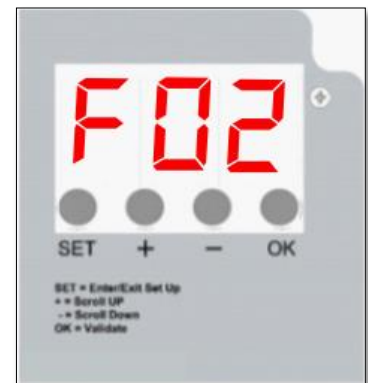

List of Parameters

Function	Min Value	Max Value	default Value
F02 Solenoid activation Time (seconds)	0,05	5,00	0,20
F03 Pause Time between solenoids activations (seconds)	001 010 (F01=3)	999	20
F04 Number of solenoids connected	01	16	01
F05 Output voltage setting (Related to hardware jumpers)	D24= Out 24Vdc A24= Out 24Vac 115= Out 115Vac 230= Out 230Vac	d24 230	A24
F06 Manual Solenoid valve activation for test	1	F04	1
F13 Amount of Post Cleaning cycles after Fan stop	0	99	1
F14 Pause Time between solenoids valve activation when in Post Cleaning cycle (seconds)	1	999	10
F15 Maintenance Time limit for warning (E11) expressed in 10th of hours	1	999	100
F16 Maintenance Time limit warning (E11)	0=Disabled 1=Enabled	0 1	0
F17 Maintenance Hour counter Reset	0=No Reset 1=Reset Counter	0 1	0
F24 Exclusion of a solenoid in case of short circuit	0=Leave the solenoid 1=Skip the solenoid	0 1	0

Description of the operations

After showing the software version at power-on, the Control Unit shows the message “---”, meaning that a diagnostic task is running to check the coherence between settings stored in the microcontroller memory and the hardware jumper’s settings.

An error code will appear in case of discrepancies between settings (see Alarms list). Only editing functions will be allowed on the Control Unit. The operator may switch-off the device, check and configure the hardware jumpers in the right manner.

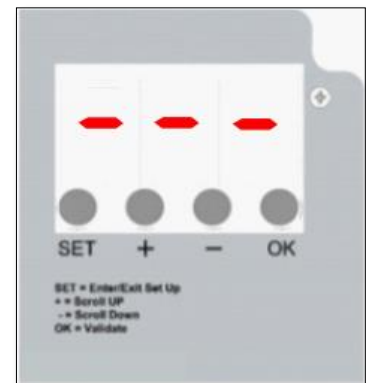

At the end of the diagnostic task, a “0_0” message will appear on the display to indicate that the test was successfully completed.

The Pause Time countdown will appear on the main screen.

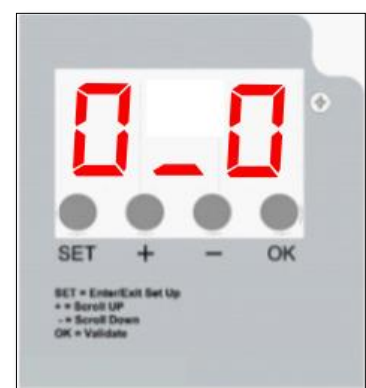

A “OFF” message appears if the “Remote EN” contact input (terminals 14-15) is open.

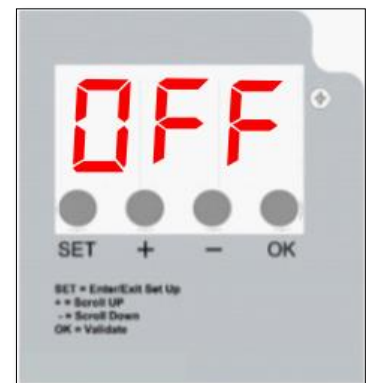

A “-0-” message appears if the “FAN Status” contact input (terminals 12-13) is open when the Control Unit is in Manual mode.

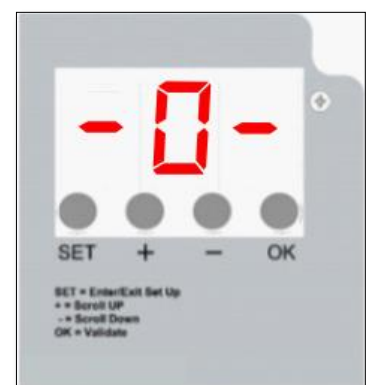

Operating Modes

MANUAL Mode

The Control Unit works as a programmable cycle sequencer.

The solenoids connected at the control unit will be activated sequentially to perform a cleaning cycle, with the timing values configured in the related parameters. After the last activated solenoid valve, the cleaning cycle will continue restarting from the first solenoid valve.

Parameters involved:

F01	0 (MANUAL)
F02	Pulse Time
F03	Pause Time

Other functions

POST CLEANING CYCLE (PCC)

This function allows to perform a cleaning cycle after the fan was stopped (OFF state) by the user.

The PCC function is enabled if the value configured in "PCC cleaning cycles" was set with a value different from zero. This parameter determines how many PCC cycles will be performed.

Parameters involved:

F13	PCC cleaning cycles
F14	PCC Pause Time

If "Fan detection mode" parameter is set to 0, the PCC function will be performed only if the Fan Status Input contact (terminals 12-13) will be opened.

The PCC Pause Time is available to be set to perform a different Pause Time than in standard cleaning cycle. The Pulse Time (F02) is the same previously set for a standard cleaning cycle.

PCC handled by "FAN OFF" input contact

The number of the PCC to perform can be set with "PCC cleaning cycles" parameter. At the end of the last PCC, the Control Unit will stop all activities until the Fan Status Input contact will be detected as closed. Then, a new standard cleaning can start, if required.

If the Fan Input Contact is detected as closed while a PCC is in progress, a new standard cleaning cycle will be started at the end of PCC, if required.

Number of solenoids connected

The number of solenoids valves connected at the Control Unit can be set. The Control Unit will run the cleaning cycle in order from the first to the last solenoid valve programmed into the parameter.

Parameters involved:

F04	Number of solenoids
-----	---------------------

Hour Counters

After showing the software version at power-on, the Control Unit

An hour counters information is available on the main screen.

The purpose is to show the total operating hours from the first power-on and the maintenance hours.

By pressing the (+) pushbutton the display will show the operating hours from the first power-on. The value can't be reset.

By pressing the (-) pushbutton the display will show the maintenance hours. The parameter F17 can be used to reset the maintenance hours.

The hours are shown on two screens.

The first screen shows the thousands of hours, the second screen shows the units of hours.

Example:

First screen count = 012

Second screen count = 345

Amount of hours = $(012 \times 1000) + 345 = 12345$

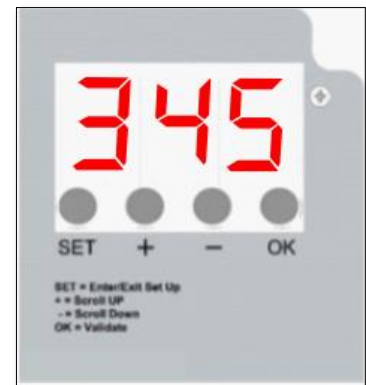

Inputs & Outputs

Inputs	Terminals	Description
Remote ENABLE contact	14-15	<p>It is used to place the Control Unit in Run or Stand-By mode.</p> <p>When the input contact is open, the Control Unit is placed in stand-By mode. No functions will be executed.</p> <p>When the input contact is closed, the Control Unit is placed in Run mode. All the functions will be executed when needed.</p> <p>The Control Unit is factory set with a wire jumper between the terminals to close the input.</p>
FAN Status contact	12-13	<p>It is used to send to the control unit the state of the fan (Running or Stopped).</p> <p>If the input contact is open, the control unit will detect the fan stopped and then run the Post Cleaning function.</p> <p>The control unit is factory set with a wire jumper between the terminals to close the input.</p>

Outputs	Terminals	Description
Alarm Relay K1	4-5	<p>The relay K1 is factory configured as normally closed contact and opens with multiple error events.</p> <p>The contact is also open when the control unit is not powered.</p> <p>The alarms events set by default for the relay are: E06 E08. Maintenance interval reached.</p>
Alarm Relay K2	6-7	<p>The relay K2 is factory configured as normally closed contact and opens with multiple error events.</p> <p>The contact is also open when the control unit is not powered.</p> <p>The alarms events set by default for the relay are: E06 E08. Maintenance interval reached.</p>

Alarms

The control Unit perform some diagnostic check at power-on and during operations.

An alarm event is shown by mean of "Exx" error code. The possible alarms and respective troubleshooting are listed in the below table:

Alarm Event	Description	Action
E01	F05 set to 24Vdc but AC jumper position detected	For 24Vdc, switch the device off and set the AC/DC jumpers to DC. For 24Vac, press OK, then press SET, set the function F05 using (+) and (-), select A24 and press OK to confirm.
E02	F05 set to 24Vac but DC jumper detected	For 24Vac, switch the device off and move the AC/DC jumpers to AC. For 24Vdc, press OK, then press SET, set the function F05 using (+) and (-), select d24 and press OK to confirm.
E03	F05 set to 24Vac or 24Vdc. Voltage Out of Range detected	To use 24V valves, switch the device off and move the output voltage selection jumper to 24V. - If the jumper is in the correct position, press OK, then SET, select the F05 function with (+) and (-), set 115 or 230 (as jumper) and press OK.
E04	F05 set to 115V. Voltage Out of Range detected	To use 115V valves, switch the device off and move the output voltage selection jumper to 115V. - If the jumper is in the correct position, press OK, then SET, select the F05 function with (+) and (-), set 115 or 230 (as jumper) and press OK.
E05	F05 set to 230V. Voltage Out of Range detected	To use 230V valves, switch the device off and move the output voltage selection jumper to 230V. If the jumper is in the correct position, press OK, then SET, select the F05 function with (+) and (-), set a24, d24 or 115 (as jumper) and press OK.
E06	Solenoid valve current lower than minimum threshold or disconnected solenoid valve. The error is displayed alternating with solenoid position Uxx failed.	Check correct connection of the solenoid valve and respective data. The alarm is auto-reset if event disappears.
E07	Solenoid valve current higher than maximum threshold. The error is displayed alternating with solenoid position Uxx failed.	Check correct connection of the solenoid valve and respective data. The alarm is auto-reset if event disappears.
E08	Short circuit alarm at output. The error is displayed alternating with solenoid position Uxx failed.	Switch the device off and back on after having checked the solenoid valve system.
E11	Maintenance deadline reached	Carry out maintenance and then reset the error.
E14	Indicates that a valve in short circuit has been excluded from the cycle. The error code E14 alternates with the indication of the failed output that is shown as "Uxx", where xx is the number of the output. An output is considered a short circuit if not responding for 3 following activations.	Switch the device off and back on after having checked the solenoid valve system.

Troubleshooting

Fault	Possible Cause	Solution
The display does not light up.	Fuse Blown. Power voltage missing.	Check the protection fuse on the power voltage. Check that the power voltage is provided at power supply terminals and compliant with that required for the device.
The outputs are not activated.	Output voltage. Wiring to solenoid valves.	Check that the solenoid valves output voltage is congruent with hardware jumper settings and programming. Check wiring between Control Unit and solenoid valves.
The cleaning cycle doesn't run	Remote Enable input is open	Check Remote Enable input contact.
Does the device occasionally reset?		Check that there are no unfiltered voltage spikes on the power line (spot welding machines, welding machines, plasma cutters etc.). Install a common-mode line filter between the Control Unit and the power line.
Does post-cleaning start during normal cleaning?	FAN OFF input is closed	Check FAN OFF
Do the alarms fail to activate relay contacts?		The relay contacts must be powered by external voltage A relay contact opens when activated by an alarm event.

Maintenance

The control unit has no parts that can be replaced, except for the fuse.

All repair operations must be carried out by the manufacturer.

To clean dust and dirt from the surfaces, gently rub with cotton or other soft cloth soaked with non-aggressive, non-abrasive detergents, use those used for glass surfaces; do not use solvents or aromatic compounds and do not rub with abrasive sponges.



Disposal

Dispose of properly after use. Dispose of the product according to laws in force for electronic equipment.

This device is for use in a dust collection system and is therefore part of a fixed installation.



Warranty

The warranty has a duration of 2 years. The company will replace any electronic component deemed defective exclusively at our workshop, except in the presence of contrary agreements to be authorized by the company.

Warranty Exclusions

The warranty will be cancelled in case of:

- Signs of unauthorized tampering or repairs.
- Incorrect use of the device not respecting technical data.
- Wrong electrical connections.
- Failure to respect system standards.
- Use not in accordance with EC standards.
- Atmospheric events (lightening, electrostatic discharges,), power surges.
- Obstructed pneumatic connections. Damaged tubes.



KLIMAWENT S.A. Poland

Chwaszczynska 194 street, 81-571 Gdynia

phone: +48 58 629 64 80

fax: +48 58 629 64 19

e-mail: klimawent@klimawent.com.pl

website: www.klimawent.com.pl

klimawent@klimawent.com.pl