

The user's manual:
IO-814FPS-EN-20240430

USE AND MAINTENANCE MANUAL



Filtering paint station FPS-1, FPS-2

814S02 FPS-1
814S04 FPS-2

1	INTRODUCTORY REMARKS	2
2	APPLICATION	2
3	RESERVATION OF PRODUCER	2
4	TECHNICAL DATA	2
5	STRUCTURE NA FUNCTION	3
6	ASSEMBLY AND START-UP	5
7	OPERATIONAL USE	5
8	TROUBLESHOOTING GUIDE	5
9	MAINTENANCE	5
10	OCCUPATIONAL HEALTH AND SAFETY	5
11	TRANSPORT AND STARGAGE	6
12	TERMS OF WARRANTY	6

1 INTRODUCTORY REMARKS

The purpose of the present Use and Maintenance Manual is to supply the User with directions within the range of application, installation, start-up and the use of the **FPS filtering paint station**. **Installing, start-up and operational use are exclusively admissible after getting acquainted with the contents of the Use and Maintenance Manual.**

Concerning the continuity of work carried out on the improvement of our products, we reserve for ourselves the revision possibility of the draft and technological changes improving their functional features and safety.

Construction of the **FPS** filtering paint station meets the requirements of the current state of technology as well as the safety and health assurances.

2 APPLICATION

FPS Filtering Paint Station is constructed as an appliance for capturing the mist arising during the painting of various not-large elements (FPS-1) and larger elements (FPS-2).

3 RESERVATION OF PRODUCER

- A. The manufacturer accepts no liability for any consequences following the operational use that is in contradiction to the purpose of the application.
- B. Installing any additional elements that do not belong to the normal device structure (or accessory set) is not acceptable.
- C. Do not undertake any structural changes or construction modifications on the device on one's own.
- D. Before installing check the load-carrying capacity of the building structure, in places where the device shall be placed.

4 TECHNICAL DATA

Table No.1 – Ventilation walls and the work table

Type	Weight [kg]
FPS-1	97
FPS-1	183
UWT	163

Table No.2 – Replaceable filters

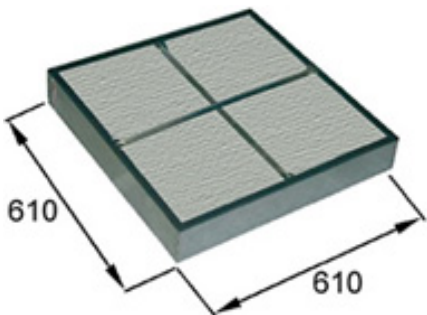
Sort of the filter	Type	Quantity
 <p>filtration cassette with spun-bond (nonwoven)</p>	KF	3 pieces for FPS-1 6 pieces for FPS-2

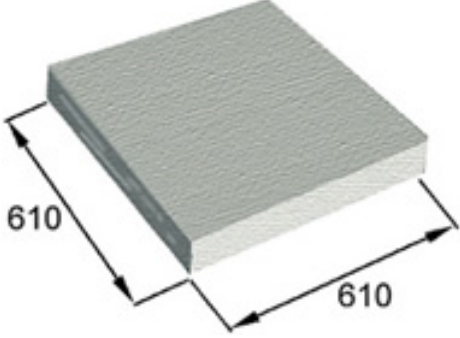
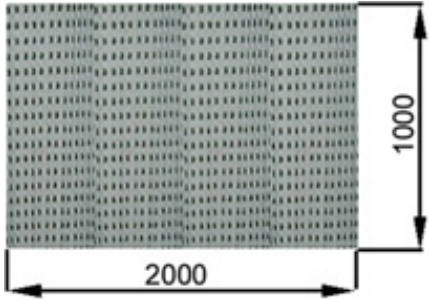
Sort of the filter	Type	Quantity
 <p data-bbox="756 315 1059 454">replaceable filtration spun-bond (nonwoven) for the cassette as above</p>	WF	3 pieces for FPS-1 6 pieces for FPS-2
 <p data-bbox="756 685 1059 752">perforated labyrinthine filter</p>	PL	1 piece for FP-1 2 pieces for FP-2

Ventilation

The paint station ought to be connected to a single fan working with one filtering paint station or cooperating with a ventilation system with one central extraction fan. As the extracted air is expelled outside the building (no recirculation), it is recommended to apply a roof fan.

5 STRUCTURE NA FUNCTION

FPS-1 is a one-segment ventilation wall, whereas **FPS-2** consists of two segments. In each segment is located a replaceable filter cartridge, providing labyrinthine airflow.

On this filter (of capture efficiency 50%) are depositing paint particles. Behind the labyrinthine filter are placed 3 spun-bond filters (FPS-1) or 6 spun-bond filters (FPS-2). Nonwoven filter operates as the second filtration stage, increasing the filtration efficiency up to 90%. Each segment of the filtering station is equipped with a connection fitting piece, discharging to the ventilation ducting. As standard, the connection piece is installed on the right side wall. The connection piece can be reinstalled to the left side wall or to the upper surface of the segment. All walls are equipped with two side swinging boards and one top swinging board.

FPS-1 paint station can be installed on a **UWT** work table, creating a universal ventilation post with a grate to put the painted elements on it and a rotary table.

The filtration walls should be connected to the extraction ventilation of flow efficiency of 3000 m³/h minimum per segment.

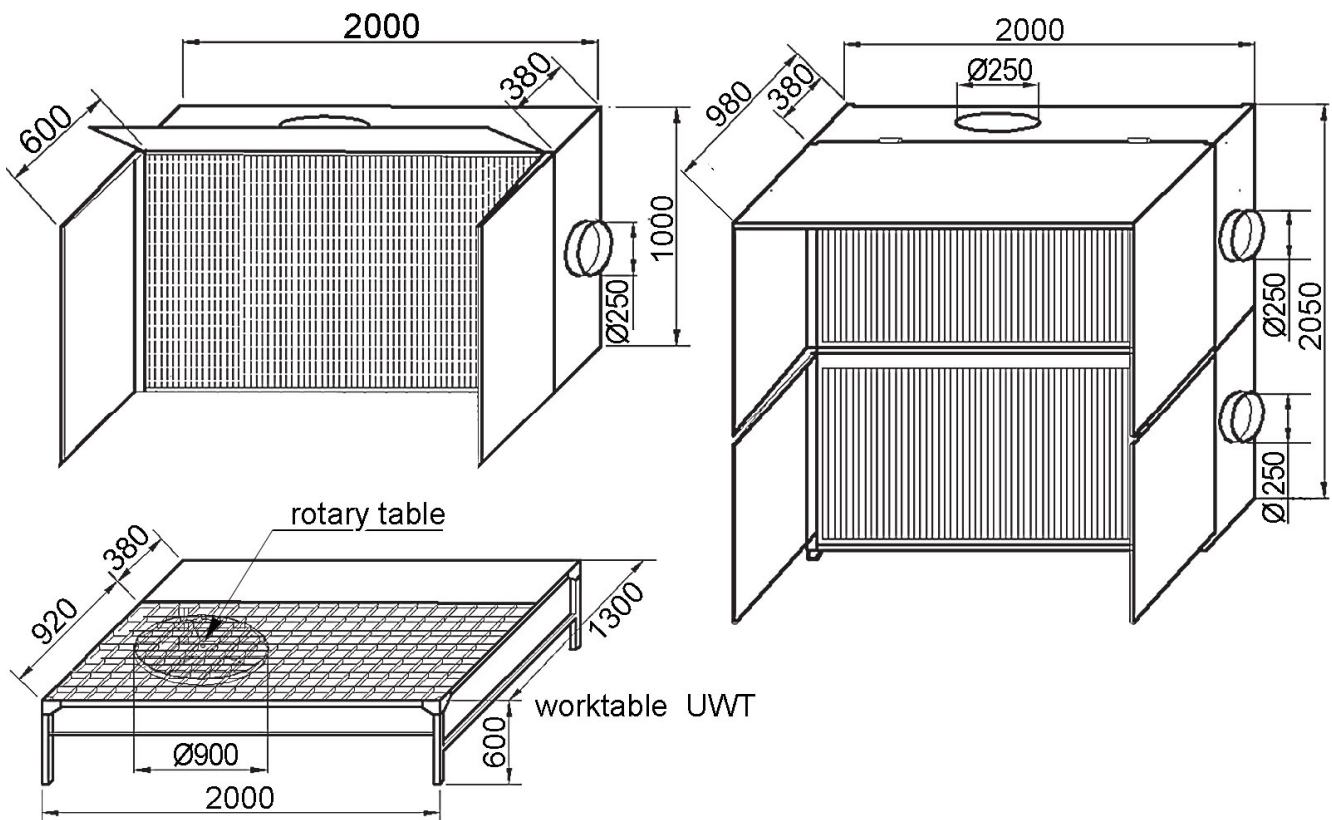
FPS-1
FPS-2
Fig. No.1 – Filtering Paint Stations for spray painting

Fig. No.2 – FPS-1, FPS-2 – Structure and dimensions

6 ASSEMBLY AND START-UP

The Filtering Paint Station ought to be installed in a place of work and connected to the extraction fan using flexible hoses of diameter Ø250 mm. To increase the extraction efficiency, the painted element should be placed near the wall as close as possible.

It is possible to put two paint walls near one another to create a ventilation station for longer elements.

CAUTION!

Filtering Paint Stations ought to be connected to the roof fans.

7 OPERATIONAL USE

In the course of operational use, it is important to control the state of filters and to keep clean the worktable (this refers to FPS-1).

8 TROUBLESHOOTING GUIDE

Table No.3

Problem	Possible reason	Corrective action
1. Decrease of the intake air volume flow	The filters are polluted	Replace the filtration spun-bond (nonwoven). If this does not improve the capture efficiency, additionally replace the labyrinthine filter.
2. Decrease in the efficiency of the extraction fan, despite the good state of the filters	The extraction fan is faulty	Examine the fan and fix the reason for failure

9 MAINTENANCE

The steps consist of periodical replacement of filters that are gradually getting polluted, as they are absorbing the contamination and the paint particles are accumulating in larger amounts.

The frequency of filter replacements should be established by experience. The decreasing flow efficiency of the extraction fan is the right moment (determinant) to replace the filters.

10 OCCUPATIONAL HEALTH AND SAFETY

Filtering Paint Station can exclusively be operated after getting acquainted with the contents of the present Use and Maintenance Manual. The appliance will not cause any hazard, provided that it is installed vertically and stably on an even floor surface.

11 TRANSPORT AND STORAGE

The appliance must be stored in dry rooms and in areas of efficient ventilation. Do not put one device on top of another (stacking).

For the time of transport, the filtering station must be placed in packages and protected against humidity, overturn and slide (displacement).

12 TERMS OF WARRANTY

The period of warranty for the purchased device is indicated in the “Card of Warranty”. The warranty does not comprise:

- device failures caused during the use which is in contradiction with the purpose of the application and with the present Use and Maintenance Manual,
- malfunction resulting from improper storage or incorrect maintenance.

Infringement of Section 3 “Reservations of Producer” of the present Use and Maintenance Manual and especially modifications undertaken by the User on one’s own or use in contradiction with the purpose of application – shall result in the loss of warranty validity.