

USE AND MAINTENANCE MANUAL



Filtering unit **STRONG-1000-N**

Contents:

1. INTRODUCTION	2
2. PURPOSE	2
3. RESERVATIONS OF MANUFACTURER	2
4. TECHNICAL DATA	2
5. STRUCTURE AND FUNCTION	3
6. ASSEMBLY AND STARTUP	3
7. OPERATIONAL USE	6
8. TROUBLESHOOTING GUIDE	7
9. MAINTENANCE AND REPAIR	8
10. OCCUPATIONAL HEALTH AND SAFETY	8
11. TRANSPORT AND STORAGE	8
12. TERMS OF WARRANTY	8
13. DECLARATION OF CONFORMITY	11

Producer: **KLIMAWENT S.A.**
 81-571 Gdynia, ul. Chwaszczyńska 194
 tel. 58 629 64 80, 58 771 43 40
 fax 58 629 64 19
 email: klimawent@klimawent.com.pl



1. INTRODUCTION

The purpose of the present Use and Maintenance Manual is to supply User with directions within the range of application, assembly, start-up and operational use of the **STRONG-1000-N** Filtering unit.



Prior to assembly at the place of operation and use, it is important to get thoroughly acquainted with the contents of the present instruction.



With regard to continuity of work carried on improvement of our products, we reserve for ourselves the revision possibility of the draft and technological changes improving their functional features and safety.

Construction of **STRONG-1000-N** meets the requirements of the current state of technology as well as the safety and health assurances included in:

the safety and health assurances included in:

2006/42/EC Directive of the European Parliament and of the Council of the 17 May, 2006 on machinery, amending the 95/16/EC Directive (recast) / Official Journal EC L157 of the 09.06.2006, page 24);

2014/35/EC Directive of the European Parliament and of the Council of the 26 February, 2014 on the harmonisation of the laws of the Member States, relating to the making available on the market of electrical equipment designed for use within certain voltage limits / Official Journal EC L96 of the 29.03.2014;

2009/125/EC (ErP) Directive of the European Parliament and of the Council of 21 October, 2009 establishing a framework for the setting of ecodesign requirements for energy-related products / Official Journal L 285 of 31.10.2009 /

327/2011 (EC) Regulation of 30 March, 2011 on implementing the **2009/125/EC Directive** of the European Parliament and of the Council with regard to ecodesign requirements for fans driven by motors with an electric input power between 125W and 500 kW / Official Journal L No.90 of 06.04.2011 /

Is in accordance with the subsequent harmonised standards:

EN ISO-12100:2012 Safety of machinery – General principles of design – Assessment and reduction of hazard

EN 60204-1:2018-12 Safety of machinery – Electrical equipment of machines – Part 1: General requirements

EN ISO 13857:2010 Safety of machinery – Safe distances to prevent hazard zones from being reached by upper and lower limbs

EN 60529:2003/A2:2014-07 Degrees of protection provided by enclosures (Code IP)

EN 61439:2011 Low-voltage switchgear and controlgear assemblies – Part 1: General resolutions

2. PURPOSE

STRONG-1000-N stationary appliance has been developed for air filtration the **dry** dust, arising during various manufacturing processes, i.e. in metal industry, chemical industry, food processing, pharmaceuticals-, plastic processing and other branches. Especially, it is appropriate for capturing the dust during grinding processes. Maximum admissible temperature of the conveyed medium is 60°C.

Due to the automatically cleaned cartridge filter (with polyester membrane) the dust particles – even smaller than 0,4 µm are captured on the outer filter surface. Here the dust particles are struck off by impulses of compressed air. **The appliance is not appropriate for removal humid dusts, aggressive substances and compounds creating explosion risk.**

3. RESERVATIONS OF MANUFACTURER

- Manufacturer is not responsible of effects resulting from the operational use that is in contradiction to the purpose of application of the device;
- Installing of any additional elements that are not belonging to the normal device structure (or accessory set) is inadmissible;
- Any structural changes / modifications, introduced on one's own are not allowed;
- Protect the device structure from mechanical damage;
- Maintenance or any repair should be carried out by an authorised person;
- The appliance cannot be used for conveying the air containing viscous and aggressive contaminants as these might damage the filters;
- **During the use, it is important to prevent ignition sources (i.e. sparks, cigarette butts / embers) from getting into the filtering unit.**

4. TECHNICAL DATA

Table No.1

Type	Supply voltage	Motor rate	Consumption of compressed air	Maximum volume flow	Maximum vacuum	Acoustic pressure level from distance		Weight	Suction connections
						1m	5m		
	[V]	[kW]	[Nm ³ /h]	[m ³ /h]	[Pa]	[dB(A)]		[kg]	
STRONG-1000-N	230	1,5	0,7	1750	2000	71*	65*	181	1 x Ø125 1 x Ø160

CAUTION:

1. Waste container capacity – 72 dm³
2. Volume flow has been measured at the clean filter
3. Assortment of the ERGO LUX extraction arms is represented on separate catalogue cards and in instructions
4. * Measurement has been carried out at the device equipped with an extraction arm

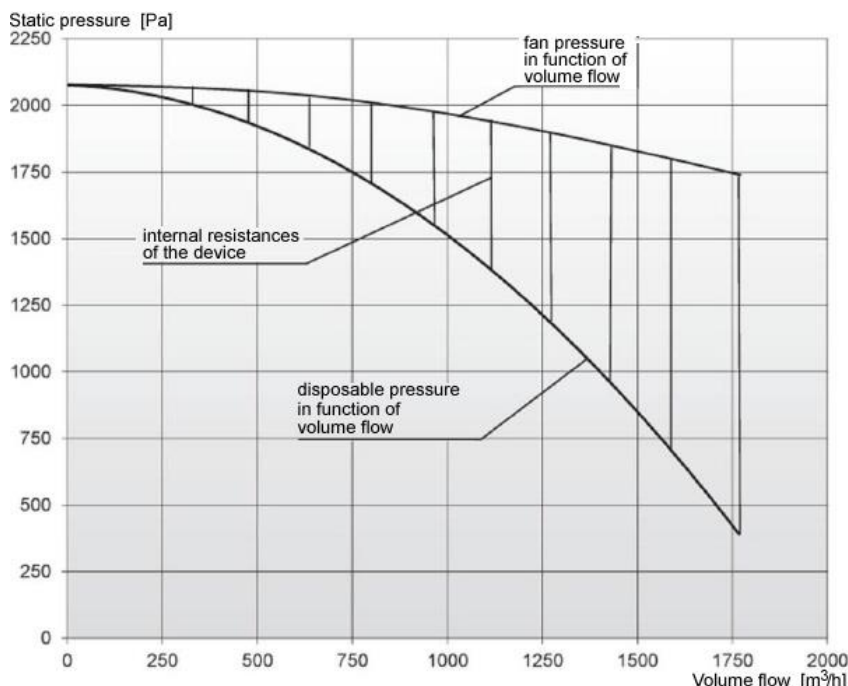



Fig. No.1 – STRONG-1000-N – Flow chart

Table No.2 – Cartridge filter

	Type	Weight [kg]	Filtration efficiency [%]	Quantity [pcs]
	PN105032T	4,2	99,9	1

5. STRUCTURE AND FUNCTION

Assemblies of STRONG-1000-N:

- steel housing – powder painted,
- radial fan – housing of cast aluminium,
- high-efficiency cartridge filter,
- pneumatic filter regeneration system – consists of compressed air tank and electromagnetic valves,
- spark catcher,
- waste container (metal case, on wheels),
- connections – to install the extraction arms or the extraction conduit system, by means of a flange coupling,
- silencer – at the fan outlet,
- control unit – to start the filtering unit (ON/OFF) and to control its function.

Waste container is equipped with a sight-glass to control its fill-up level state.

6. ASSEMBLY AND STARTUP

STRONG-1000-N is meant for use in closed rooms (indoor application). As the appliance is delivered in a disassembled state, beforehand install the extraction fan and the elbow with a silencer. Installing is illustrated in Fig. No.3. The fan ought to be installed by means of eight bolts **M8x25**, whereas the silencer by four screws **4.2x13**. Put the device stably on an even floor surface. Important is that the operator has free access to the control unit and to the waste container. From the external installation, supply **dry** compressed air, without contamination, free from oil and humidity – of pressure above 6 bar, but not exceeding 8 bar. Plug the device into the 230V socket. The appliance must be equipped with local extraction elements (ERGO LUX extraction arms or hoses).

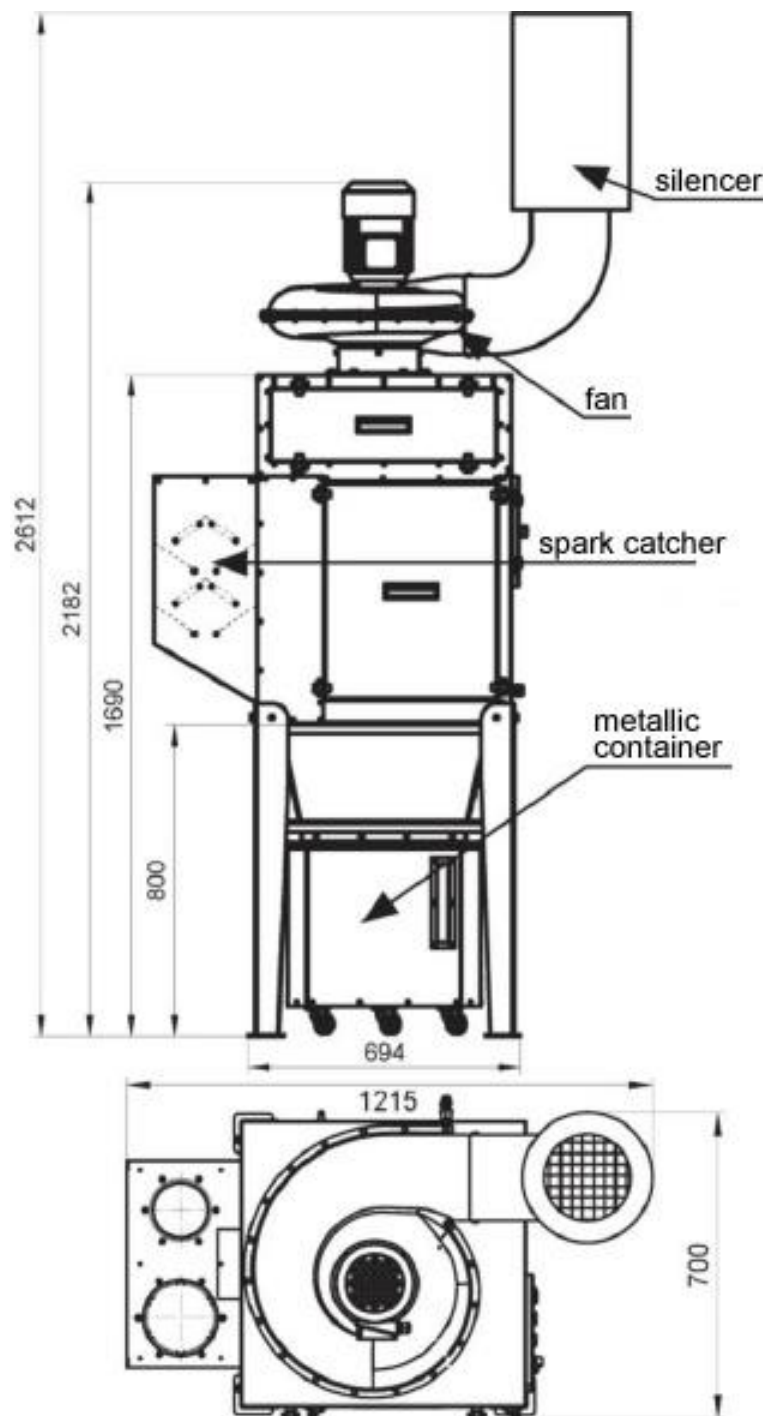

Fig. No.2 – STRONG-1000-N – Structure and Dimensions

- extraction arm **ERGO LUX-L** – connected by means of $\varnothing 160$ coupling (the $\varnothing 125$ connection ought to be closed with a plug).
- extraction arms **ERGO LUX-K** (2 pieces) – should be installed on the connection $\varnothing 125$ (and on the $\varnothing 160$ connection after a reducing flange is introduced).

After the connection fitting pieces are installed, it is possible to fasten flexible hoses (instead of the ERGO LUX extraction arms).

Within the range of start-up, it is important to connect the device with the power supply and make connections to the control unit, according to the enclosed Connection Diagram (see Fig. No.4). **Any activities of device connection to the power supply system should be performed by an authorised person with electrical qualifications.**

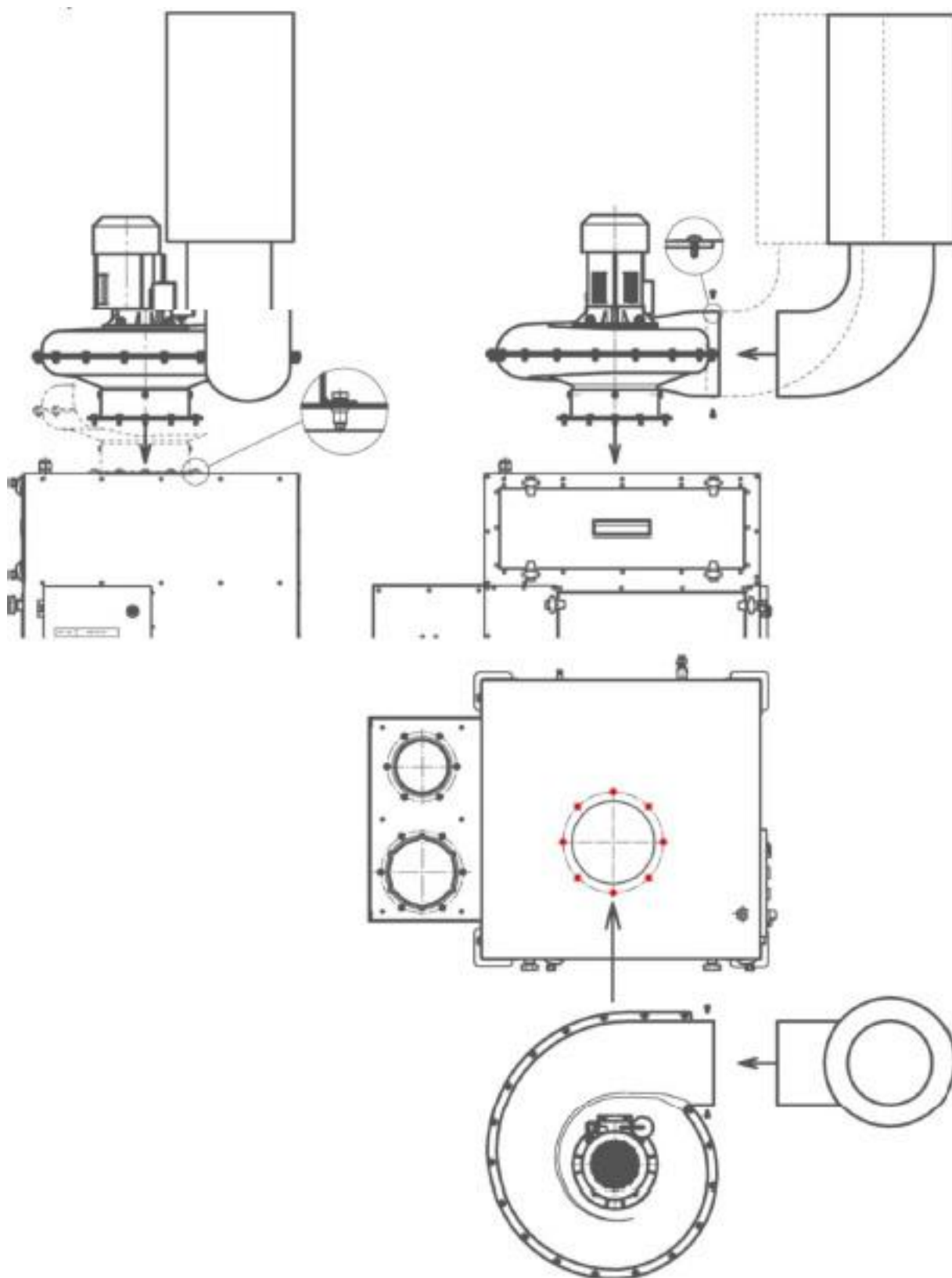

Fig. No.3 – STRONG-1000-N – How to install the fan and the elbow

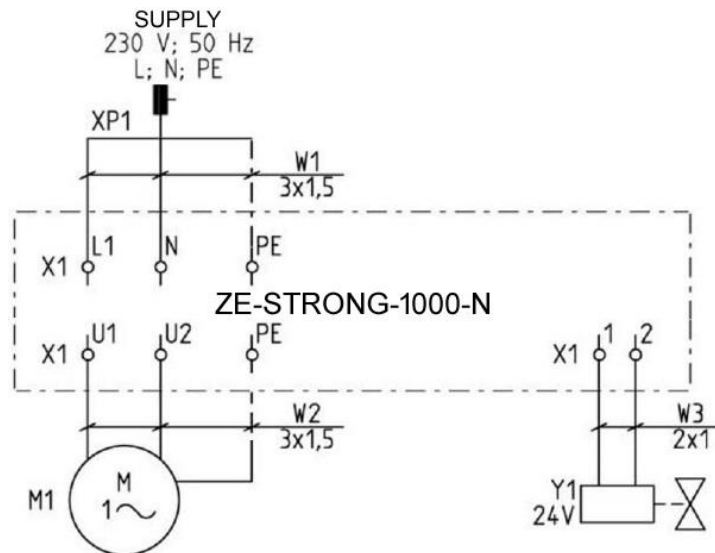

Fig. No.4 – STRONG-1000-N – Connection Diagram

7. OPERATIONAL USE

ZE-STRONG-1000-N control unit is delivered along with the device and is applied as an control item for the unit.

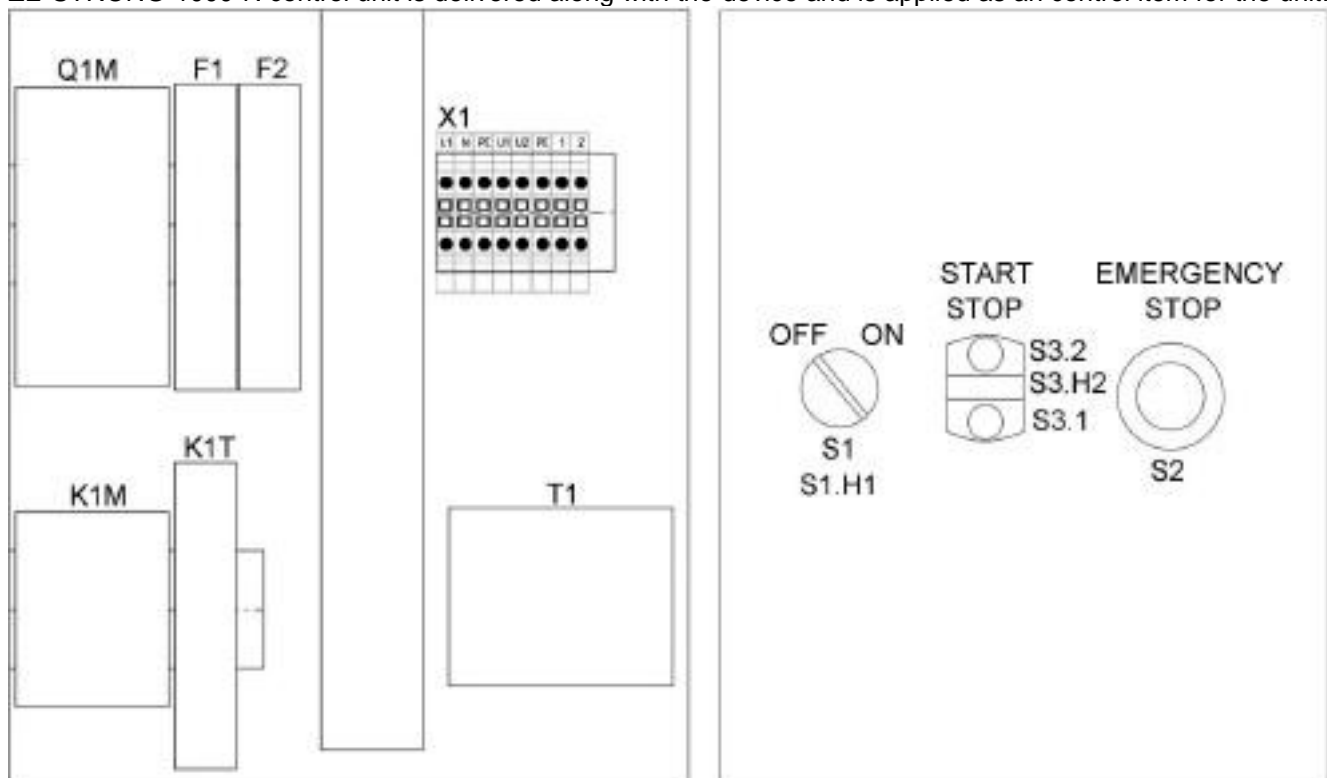

Fig. No.5 – ZE-STRONG-1000-N – Control unit

START-UP OF APPLIANCE:

1. Open the compressed air valve.
2. Insert the plug into the supply socket.
3. Switch on the motor protective switch **Q1M** inside the control unit (see Fig. No.5).
4. Switch on the power supply by setting the **S1** into position "ON"; as indicated by the white lamp **S1.H1**.
5. The filter cleaning system is active as long as the power supply of the device is switched on. Every 4 minutes the **K1T** time relay emits a 0,5s impulse to open the **Y1** electromagnetic valve to clean the filter with the compressed air.

FUNCTION OF THE DEVICE:

1. Press the **S3.2** "START" pushbutton; the fan starts – this will be indicated by the **S3.H2** green lamp "FAN".
2. The appliance is in operation, the filter is cleaned every 4 minutes. The electromagnetic valve opens every 4 minutes.

DISCONNECTION OF THE DEVICE:

1. Press the **S3.1** "STOP" button; the **S3.H2** "FAN" lamp goes off; The filter regeneration system is still working.
2. Disconnect the power supply by setting the **S1** switch into position "OFF"; The white lamp **S1.H1** "SUPPLY" will go off. The filter regeneration system stops working.
3. Unplug the filtering unit.

When the device must be necessarily disconnected, press the **S2** pushbutton “**EMERGENCY STOP**”. The control system will get disconnected.

High efficiency and cleaning of the filters by repeating impulses of compressed air, provides satisfactory longevity of the filter cartridges and limits the maintenance to the minimum.

During the use, the cartridge filters are cleaned by the impulses of compressed air, whereby the **K1T** time relay is adjusted in subsequent parameters:

- impulse time – **T1** – 0,5 second
- idle time (break between the impulses) – **T2** – 4 minutes.

Do not change the settings on the time relay. Contact KLIMAWENT S.A. if necessary. In case when intake air volume flow decreases, (despite the correctly functioning filter regeneration system) – take out the filter cartridge, check if it is damaged and clean it from the deposited dust when necessary.

The filters can be cleaned in a “dry method” – by blowing the deposited dust particles off, using a compressed air stream. **If the filter is damaged, replace it into a new.**

The construction of the fan and motor ensures reliable function without the routine everyday technical supervision. In case when the device is functioning improperly, undertake its technical revision (see Section 8).

Any repair or revisions ought to be carried out at the device disconnected from the power supply system.

User’s Manual and adjustment of the ERGO LUX extraction arms:

Before the use, install the ERGO LUX extraction arm on the device and subsequently:

- Set the hood inlet in a suitable position appropriate for fume- and dust control and simultaneously in a position that is not creating barrier to operator’s movement and not limiting the field of view at the workplace.
- By turning the lever of the shut-off damper it is possible to adjust the volume flow of the inlet air – in order to control best the dustiness / contamination and, on the other hand, not to produce excessive draught.
- In the course of operational use, the position of the hood, the extraction arm and of the shut-off damper – can be changed many times, to adapt them best for the operators current requirements.

After the completed work with the ERGO LUX extraction arms

- Leave the extraction arm in the ultimately used position, if this does not cause barrier to personnel / people in vicinity.
- Switch off the fan or the extraction ductwork installation. In application where the device works with the stationary extraction system, close the shut-off damper in the hood.

Caution:

In each joint of the ERGO LUX extraction arm is built-in a frictional element to obtain the balance and self-supporting properties of the extraction arm, to keep a stable position of the arm during the use. The adjustment of the elements is executed by increasing or reducing the pressure of the disk springs onto the frictional elements. To increase the frictional moment, tighten up the nuts, whereas releasing of them causes reduction of the moment.

The adjustment of the frictional elements in the subsequent joints ought to be carried out in such a way that guarantees the balance and self-supporting features of the device (which is important to keep the suitable and stable arm position during the operation), and on the other hand, this cannot cause any excessive resistance while User is changing the position of the extraction arm.

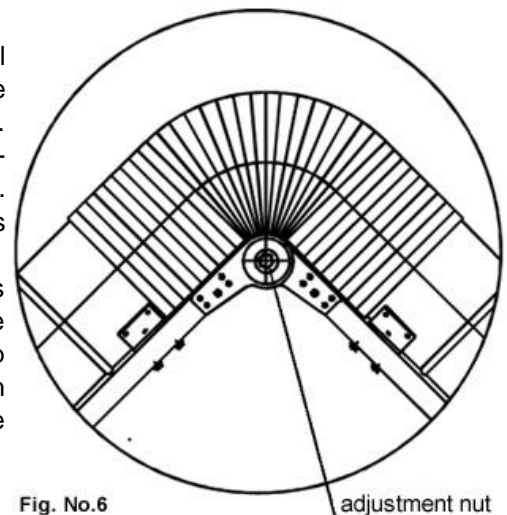

Fig. No.6

8. TROUBLESHOOTING GUIDE

Table No.3a

	Problem	Possible reason	Corrective action
1.	The intake air volume decreases	The filters are clogged	Clean the surface of the filters from dust by a “dry method” – see Section 7
2.	Dust emerges inside the housing of the electromagnetic valves	Cartridge filter is faulty	Replace the faulty cartridge filter for new
3.	Abrupt vibrations of the fan occur	The impeller is damaged	Replace the impeller for a new
4.	ERGO LUX extraction arm falls	Incorrectly adjusted frictional brake in the joint	Carry out adjustment of the frictional brake by tightening the adjustment nuts
5.	The extraction arm sets automatically always in the same position	The swivel rotation axis is not positioned vertically	Set the rotation axis into vertical position by levelling the mounting flange of the extraction arm or put the whole device on the even floor

Table No.3b

	Problem	Possible reason	Corrective action
6.	The fan does not switch on	Protections Q1M, F1, F2 are switched off	Check the reasons of activation of the protections. Switch on the mentioned protections

9. MAINTENANCE AND REPAIR

High efficiency and filter cleaning by means of repeated impulses of compressed air, provide longevity of the cartridge filter and as well limits the maintenance to the minimum. The filter cleaning proceeds automatically, without work interruption, and without the flow efficiency loss. The construction of the device ensure its operational use without continuous routine everyday technical supervision. In case when defective function is by noise or visually noticed – undertake its revision (see Table No.3).

Every 12 months, check the technical state of the device, according to the detailed principles of the operational use of the electrical driving devices.

During the maintenance check the: mechanical, electrical as well as pneumatic connections.

Any repair or revisions ought to be performed exclusively at the device disconnected from the power supply system. Once a year, check the state of the compressed air tank, especially check if there aren't any corrosion decrements (losses) decreasing the thickness of the tank walls and bottoms. If significant corrosion losses are observed, replace the tank for a new one. Frequency of replacement of the cartridge filter is depended on the technical conditions of operational use.

10. OCCUPATIONAL HEALTH AND SAFETY

Operational use of the filtering unit is exclusively possible after getting acquainted with the contents of the present Use and Maintenance Manual. For the safety reasons, connect the device to the power supply according to the being in force regulations within the range of personal protection against the electrical shock and the short-circuit-and overload effects. **Any connection activities ought to be performed by a person of adequate electrical qualifications.**

Circuits of the sockets ought to have differential current protection (see the Connection diagram). The filtering unit meets the safety requirements included in the 2006/42/EC Directive and do not require additional protections for safe operational use.

Any maintenance / repair activities carried out on the appliance, are possible after the device is switched off and disconnected from the power supply system. Additionally, prior to opening the control unit case disconnect the appliance from the power supply system.

11. TRANSPORT AND STORAGE

STRONG-1000-N filtering unit is transported on a pallet, protected with foil against atmospheric factors. Due to significant device dimensions (its height), the extraction fan, silencer with the elbow are disassembled for the transport time. The extraction fan is placed close to the device on the same pallet, whereas the silencer and elbow on the device.

During the transport, the filtering unit must be in vertical position and protected against overturn, knocking down and uncontrolled displacement/slide. The appliance has to be stored in a dry and well ventilated room.

12. TERMS OF WARRANTY

The period of warranty for the purchased device is indicated in the Card of Warranty. The warranty does not comprise:

- device failures caused during the use which is in contradiction with the purpose of application and with the present Use and Maintenance Manual;
- mechanical damage and malfunctions caused by User;
- changes and adaptations carried out by user on one's own;
- malfunctions resulting from the improper transport, storage or incorrect maintenance;
- inefficiencies resulting from the normal device wear / operational exhaustion.

Infringement of the principles contained in the present Use and Maintenance Manual causes the validity loss of the warranty.

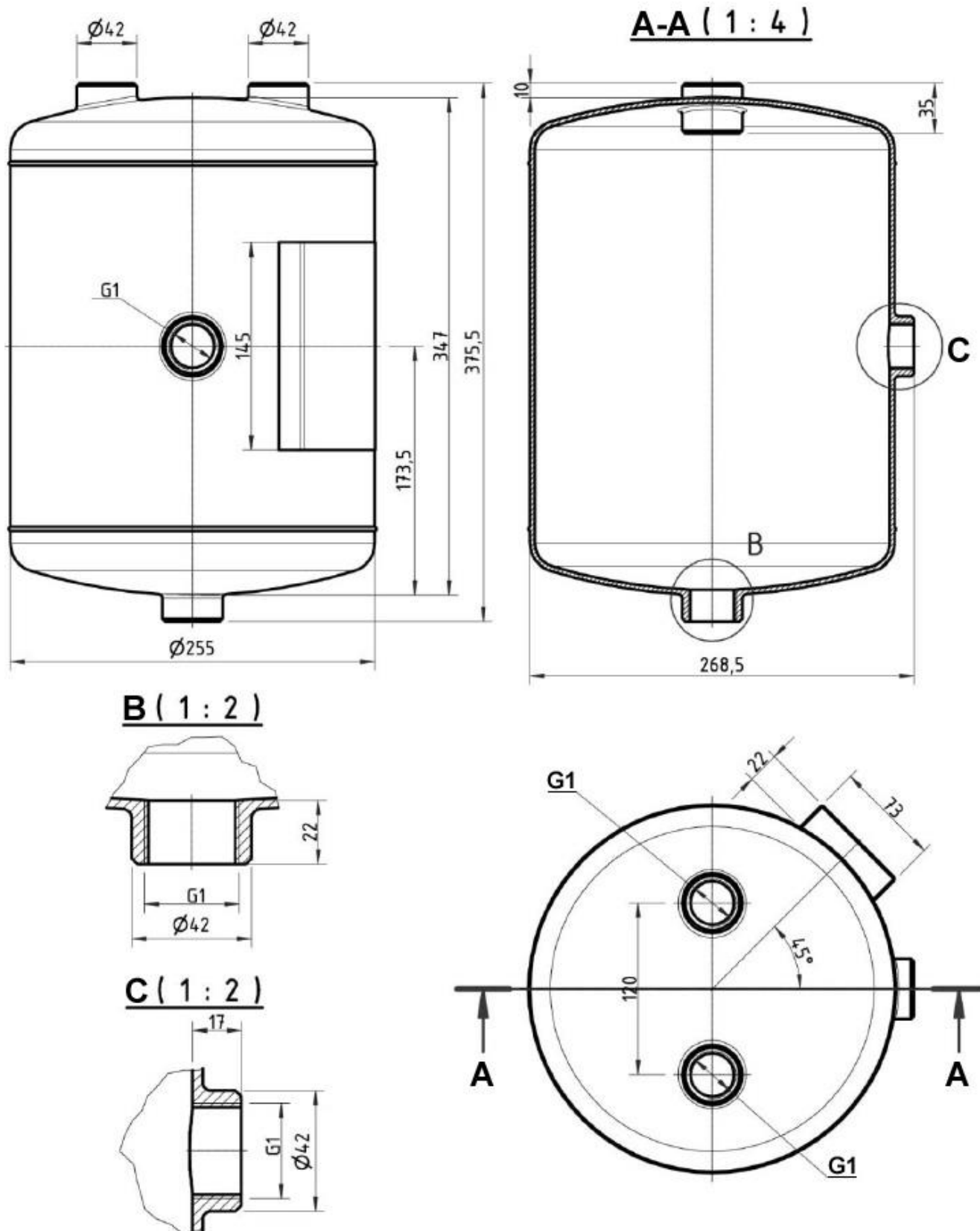

Fig. No.7 – Compressed air tank

Instruction for the compressed air tank

I. Technical data of the tank

- type: 35 – 35
- maximum operational pressure: $P_s = 10,0$ bar
- maximum operational temperature: $T_{max} = 100^\circ\text{C}$
- minimum operational temperature: $T_{min} = -40^\circ\text{C}$
- capacity of the tank: $V = 15$ dm²

II. Range of application

The tank is designed for use in pneumatic systems. The operational medium can be compressed air of work pressure equal or below the P_s pressure.

III. Conditions of installing and maintenance

1. The tank can be installed in the pneumatic systems where the operational medium is the compressed air and the highest pressure does not exceed the operational pressure P_s of the tank. **This condition ought to be fulfilled by the company which is installing the tank.**
2. The tank ought to be installed in a way ensuring durability, tightness and in such a configuration that the outlet connection is positioned at the bottom location of the tank.
3. The tank has to be fastened to the supporting structure and positioned in such a location where it would not be exposed to outer factors and to direct mechanical destructions and simultaneously during the operational use it should not be exposed to vibrations that could contribute to a fatigue crack.
4. During any technical revision or repair (carried out on the pneumatic installation) it is important to check the correctness and the state of the tank mounting – i.e. screw connections, welds and their technical state.
5. If there is a damage in the wall (crack, indentation, infringement of the mounting stability, etc.) and the tank was relatively exposed to extreme temperatures that could change the structure of the wall material – **it ought to be immediately excluded from operational use.**
6. Do not disassemble (take off) the tank or its structural parts, while it is under pressure or the supply valve of compressed air is open. Any maintenance or cleaning of the tank ought to be executed when the tank is emptied and disconnected from the control unit of the installation.
7. Do not execute any welding works close to the tank.
8. During the technical revisions the tank ought to be emptied from condensate water through the drainage device in the bottom part of the tank.
9. For the maximum operational life of the tank is granted 40 years of warranty due to thickness loss of the walls that under corrosion could occur.

Any changes or modifications on the tank and operational use that is inconsistent to purpose of application are forbidden.

13. DECLARATION OF CONFORMITY



DECLARATION OF CONFORMITY EC No. _____

Manufacturer (eventually also the authorised representative / importer):

name: **KLIMAWENT S.A.**

address: **81-571 GDYNIA, ul. Chwaszczyńska 194**

A person, authorised for issuing the technical documentation:

name and address: Teodor Świrbutowicz, **KLIMAWENT S.A.**

hereby declares that the product: **Filtering unit**

type / model: **STRONG-1000-N**

serial number: _____

year of production: _____

Meets the requirements of the subsequent European Directives:

2006/42/EC Directive of the European Parliament and of the Council of the 17 May, 2006 on machinery, amending the 95/16/EC Directive (recast) / Official Journal EC L157 of the 09.06.2006, page 24);

2014/35/EC Directive of the European Parliament and of the Council of the 26 February, 2014 on the harmonisation of the laws of the Member States, relating to the making available on the market of electrical equipment designed for use within certain voltage limits / Official Journal EC L96 of the 29.03.2014;

2009/125/EC (ErP) Directive of the European Parliament and of the Council of 21 October, 2009 establishing a framework for the setting of ecodesign requirements for energy-related products / Official Journal L 285 of 31.10.2009 /

327/2011 (EC) Regulation of 30 March, 2011 on implementing the **2009/125/EC Directive** of the European Parliament and of the Council with regard to ecodesign requirements for fans driven by motors with an electric input power between 125W and 500 kW / Official Journal L No.90 of 06.04.2011 /

is in accordance with the requirements of the following harmonised standards:

EN ISO-12100:2012 Safety of machinery – General principles of design – Assessment and reduction of hazard

EN 60204-1:2010 Safety of machinery – Electrical equipment of machines – Part 1: General requirements

EN ISO 13857:2010 Safety of machinery – Safe distances to prevent hazard zones from being reached by up-per and lower limbs

EN 60529:2003/A2:2014-07 Degrees of protection provided by enclosures (Code IP)

EN 61439:2011 Low-voltage switchgear and controlgear assemblies – Part 1: General resolutions

place, date

*signature of the
authorised person*

*name, surname,
function of the signatory*

NOTES: