

Use and Maintenance Manual



Hanging Extraction Arm ERGO LUX

Product no.	Name of product
810R70	ERGO LUX-M-1,5
810R71	ERGO LUX-M-2
810R72	ERGO LUX-K-2
810R73	ERGO LUX-K-3
810R74	ERGO LUX-L-2
810R75	ERGO LUX-L-3
810R76	ERGO LUX-L-4
810R77	ERGO LUX-D-2
810R78	ERGO LUX-D-3
810R79	ERGO LUX-D-4
809R02	ERGO LUX-LL-2
809R03	ERGO LUX-LL-3
809R04	ERGO LUX-LL-4
809R05	ERGO LUX-DL-2
809R06	ERGO LUX-DL-3
809R07	ERGO LUX-DL-4

V.04.03.2024

Contents

1.	INTRODUCTORY REMARKS	3
2.	APPLICATION	3
3.	RESERVATIONS OF PRODUCER	3
4.	TECHNICAL DATA	4
5.	STRUCTURE AND FUNCTION.....	9
6.	ASSEMBLY AND START-UP	9
7.	OPERATIONAL USE	10
8.	TROUBLESHOOTING GUIDE	11
9.	MAINTENANCE	11
10.	OCCUPATIONAL HEALTH AND SAFETY	11
11.	TRANSPORT AND STORAGE	12
12.	TERMS OF WARRANTY.....	12
13.	ASSEMBLY INSTRUCTION OF EXTRACTION ARMS.....	13
14.	SAMPLE OF THE DECLARATION OF CONFORMITY.....	16

1. INTRODUCTORY REMARKS

The purpose of the present Use and Maintenance Manual is to supply the Purchaser and the future User with directions within the range of application, installation, start-up and operational use of the **ERGO LUX** extraction arms.

Therefore, installation, start-up and operational use are exclusively admissible after getting acquainted with the contents of the Use and Maintenance Manual. With regard to the continuity of work carried out on the improvement of our products, we reserve for ourselves the revision possibility of the draft and technological changes improving their functional features and safety.

The construction of the **ERGO LUX Extraction Arm** meets the requirements of the current state of technology as well as the safety and health assurances included in:

- **2006/42/EC Machinery Directive** of the European Parliament and of the Council of 17 May 2006 on machinery – amending the 95/16/EC (recast) (Journal of Laws EC L157 of 09.06.2006, page 24).

The device has been constructed and produced based on the following harmonized standards:

- **EN ISO 12100:2012** – Safety of machinery – Basic concepts, general principles for design. Risk assessment and risk reduction.

2. APPLICATION

Extraction Arm type **ERGO LUX** has been developed for capturing the welding dust particles and welding gas and also other fine dust particles, directly at the emission source, to avoid the contamination expanding within the process room/hall and to protect the people in the vicinity from inhaling the the the contamination.

The extraction arms are manufactured in hanging and standing versions. They can work independently, in a single configuration with one extraction fan, or a group of extraction arms, connected to the main collecting ductwork (with a central fan).

3. RESERVATIONS OF PRODUCER

- A. The producer is not responsible for failures arising during the use that is inconsistent with the purpose of application.
- B. Installing any additional elements not belonging to the normal device structure (or accessory set) is not acceptable.
- C. Any structural changes or modifications of the unit carried out by the User on one's own are not permitted.
- D. Protect the flexible elements and the suction duct segment (pipe) from mechanical damage.
- E. Before installing examine the load capacity of the wall or other building structure at points where the device shall be mounted. Unsure mounting could cause a hazard to personnel/people in the vicinity, as well as damage to the device itself.
- F. Do not use the device for conveying the air mixture with combustible substances, in the form of gas, vapour, mist or dust – that might create an explosive atmosphere.
- G. Do not apply the device for conveying the air containing viscous compounds that would deposit on the surface of the device elements.
- H. Do not apply the device to conveying the air containing aggressive compounds that would have a destructive effect on the device elements.
- I. Maximum allowable negative pressure in the ventilation system cannot exceed **800 Pa** for **ERGO LUX-M; -K; -L** arms and **1400 Pa** for **ERGO LUX-D** arms, otherwise the negative pressure may damage the hoses.

4. TECHNICAL DATA

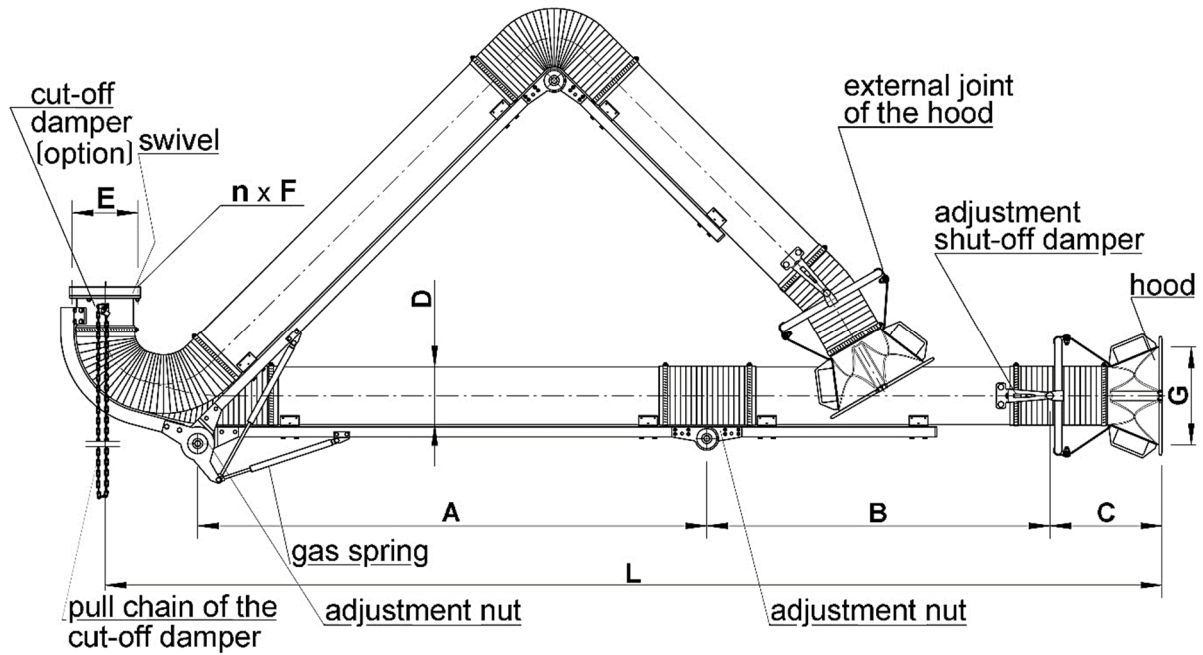

Fig. No.1 – Extraction Arms type ERGO LUX – Dimensions and Structure

Table No.1 – Extraction Arms type ERGO LUX – Dimension, weight

Remarks	Type	Dimensions								Mass [kg]				
		D _n [mm]	L [m]	A [mm]	B [mm]	C [mm]	E [mm]	n x F [mm]	G [mm]					
hanging version	standard hood	ERGO LUX-M/1,5	100	1,8	630	555	335	Ø165	6 x Ø6,5	Ø235	10,0			
		ERGO LUX-M/2		2,2	960	675					11,0			
		ERGO LUX-K/2	125	2,3	1055	650					12,5			
		ERGO LUX-K/3		3,0	1540	915					14,0			
		ERGO LUX-L/2	160	2,3	905	790					Ø194	Ø295	17,5	
		ERGO LUX-L/3		3,15	1530	1030							19,5	
		ERGO LUX-L/4		3,8	1910	1260							22,0	
	hood with a spot-light	ERGO LUX-D/2	200	2,3	905	790		Ø246	8 x Ø8,5	Ø335	19,0			
				ERGO LUX-D/3	3,15	1530					1030	22,5		
				ERGO LUX-D/4	3,8	1910					1260	25,0		
		ERGO LUX-LL/2	160	2,3	905	790					Ø194	6 x Ø6,5	Ø295	17,5
		ERGO LUX-LL/3		3,15	1530	1030								19,5
		ERGO LUX-LL/4		3,8	1910	1260								22,0
		ERGO LUX-DL/2	200	2,3	905	790					Ø246	8 x Ø8,5	Ø335	19,0
ERGO LUX-DL/3	3,15			1530	1030	22,0								
ERGO LUX-DL/4	3,8			1910	1260	25,0								

Extraction arms type **ERGO LUX-LL** and **ERGO LUX-DL** are equipped with hoods with halogen spotlights. For information about the connection of the lighting see the connection diagram enclosed in the present Use and Maintenance Manual (see Fig. No.4).

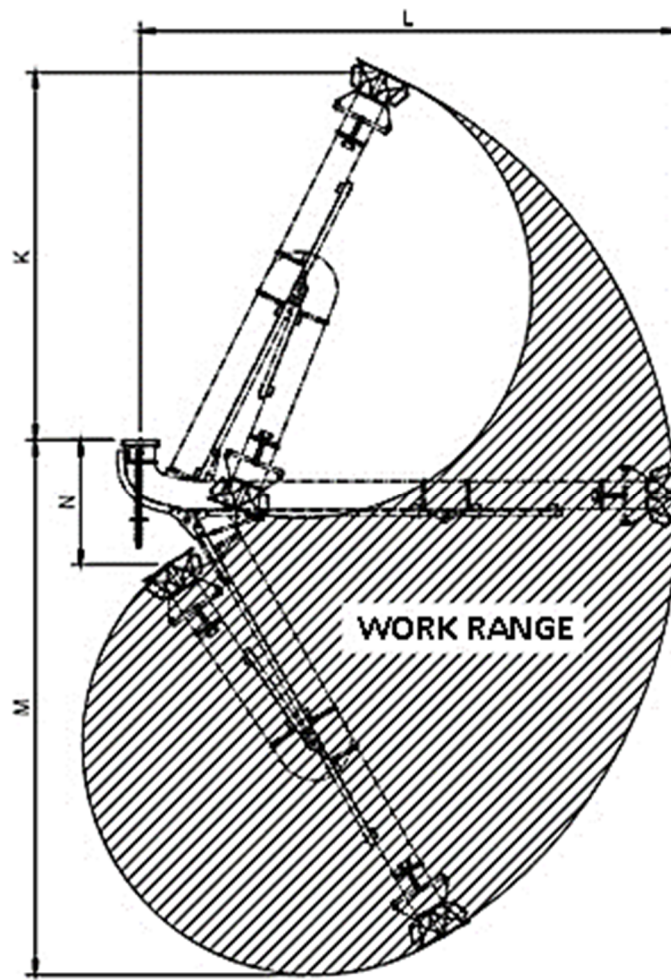

Fig. No.2 – Work ranges of the extraction arms

Table No.2 – Dimensions of the work ranges of the extraction arms

Type	K [m]	M [m]	N [m]	L [m]
ERGO LUX-L(L)/2	1,4	2,4	0,6	2,3
ERGO LUX-D(L)/2				
ERGO LUX-L(L)/3	2,2	3,2	0,75	3,2
ERGO LUX-D(L)/3				
ERGO LUX-L(L)/4	2,7	3,7	1,2	3,8
ERGO LUX-D(L)/4				

Table No.3 – Hoods for the ERGO LUX extraction arms

Sort of the hood	Material	Type	Z [mm]	T [mm]	H [mm]	Mass [kg]	Application	Equipment
	plastic ABS	MST	330	100	190	0,35	ERGO LUX-M/1,5 ERGO LUX-M/2	– replaceable inlet wire-mesh
		KST	330	125		0,36	ERGO LUX-K/2 ERGO LUX-K/3	
		LST	365	170		0,42	ERGO LUX-L/2 ERGO LUX-L/3 ERGO LUX-L/4	
		DST	415	210		0,53	ERGO LUX-D/2 ERGO LUX-D/3 ERGO LUX-D/4	
		LLT	365	170		0,45	ERGO LUX-LL/2 ERGO LUX-LL/3 ERGO LUX-LL/4	– replaceable inlet wire-mesh
		DLT	415	210		0,55	ERGO LUX-DL/2 ERGO LUX-DL/3 ERGO LUX-DL/4	– halogen spotlight 12V – switch

Table No.4 – Inlet wire mesh for the hoods

	Type	P [mm]	Application	Mass [kg]
	DST	~ø410	hood DST	0,15
	LST	~ø360	hood LST	0,10
	MKST	~ø320	hood MST hood KST	0,08
	LLT	~ø360	hood LLT	0,09
	DLT	~ø410	hood DLT	0,14

Table No.5 – Wall bracket – additional element of the device

Sort of the bracket	Material	Type	S [mm]	Mass [kg]	Cooperating extraction arms
	steel sheet	WBN-125-K	250	3	ERGO LUX-M ERGO LUX-K
		WBN-160-L	320	4,6	ERGO LUX-L
		WBN-200-D	340	6,1	ERGO LUX-D

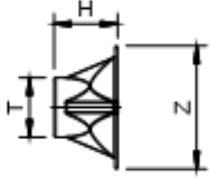
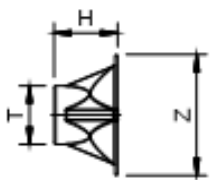
4.1 FLOW DIAGRAMS OF ERGO LUX EXTRACTION ARMS

ERGO LUX-M

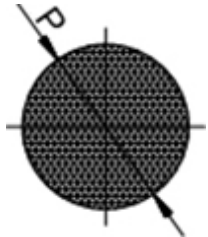
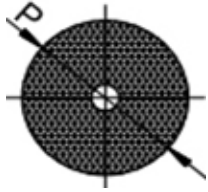
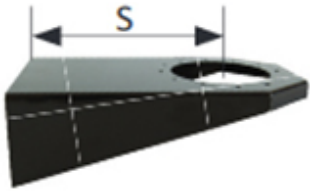
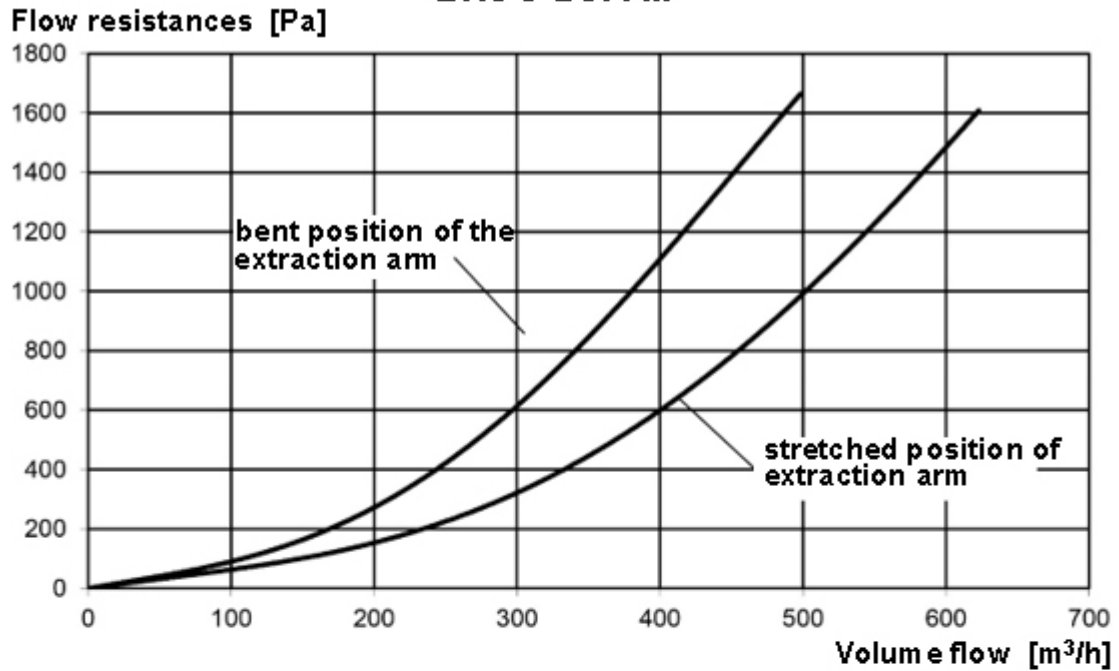

ERGO LUX-K

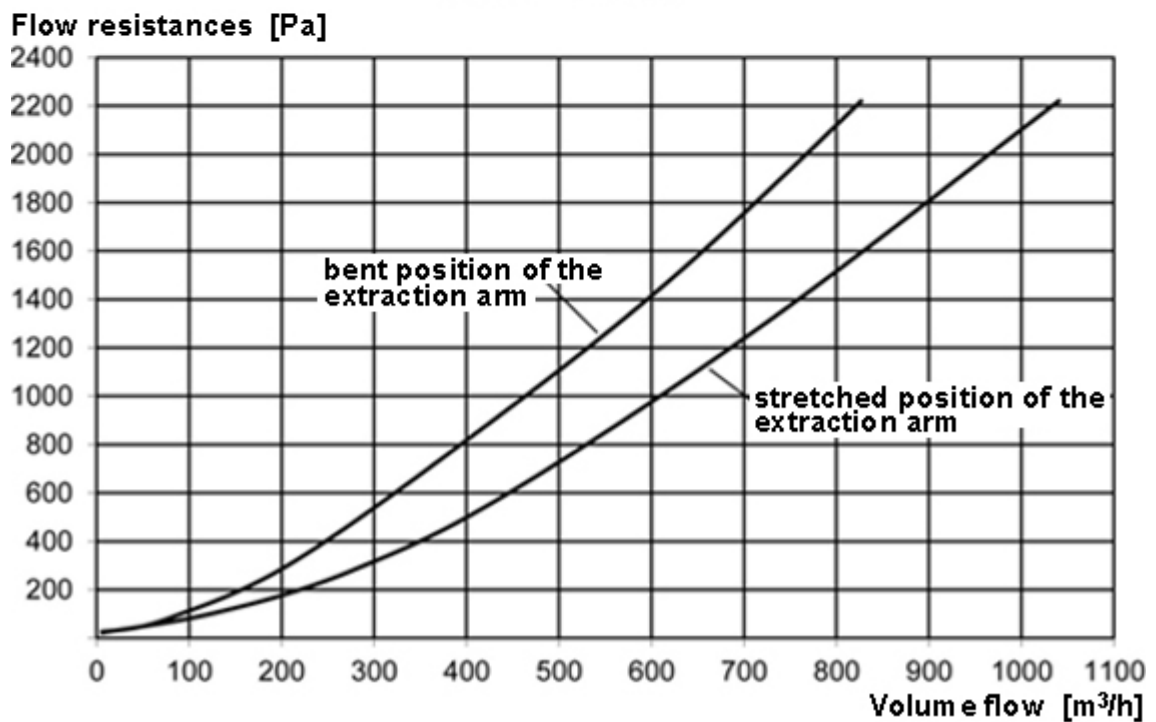

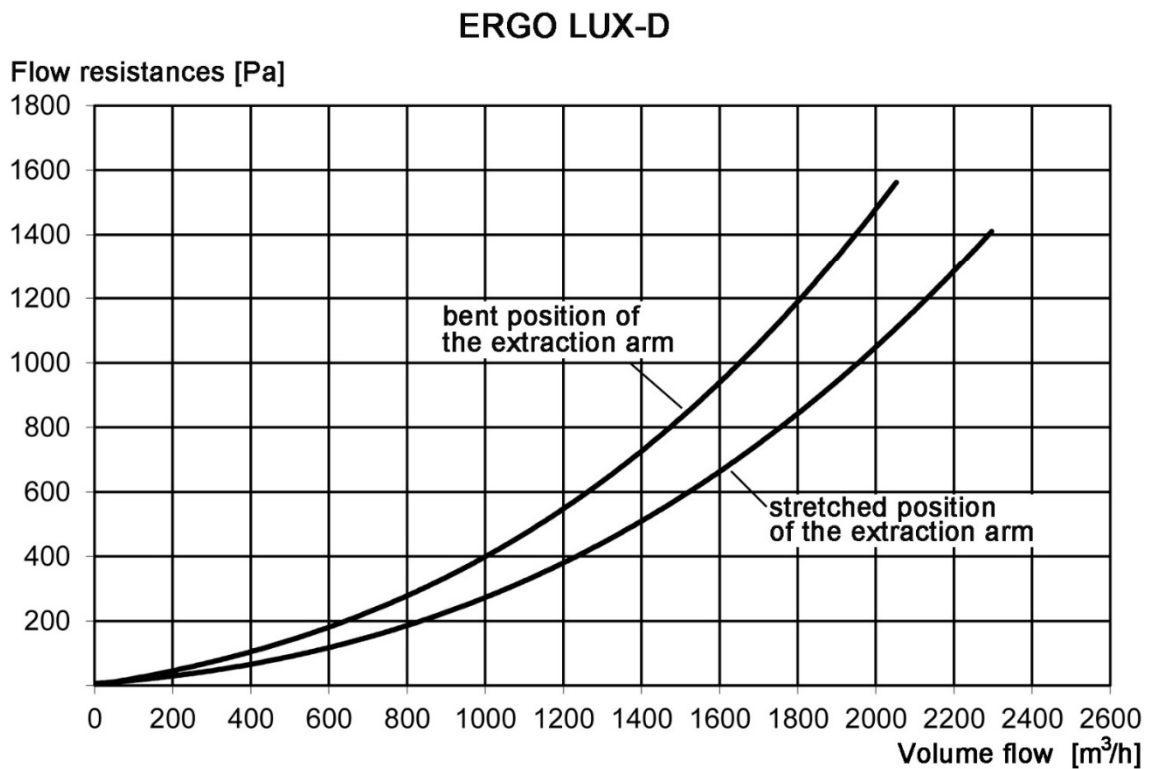
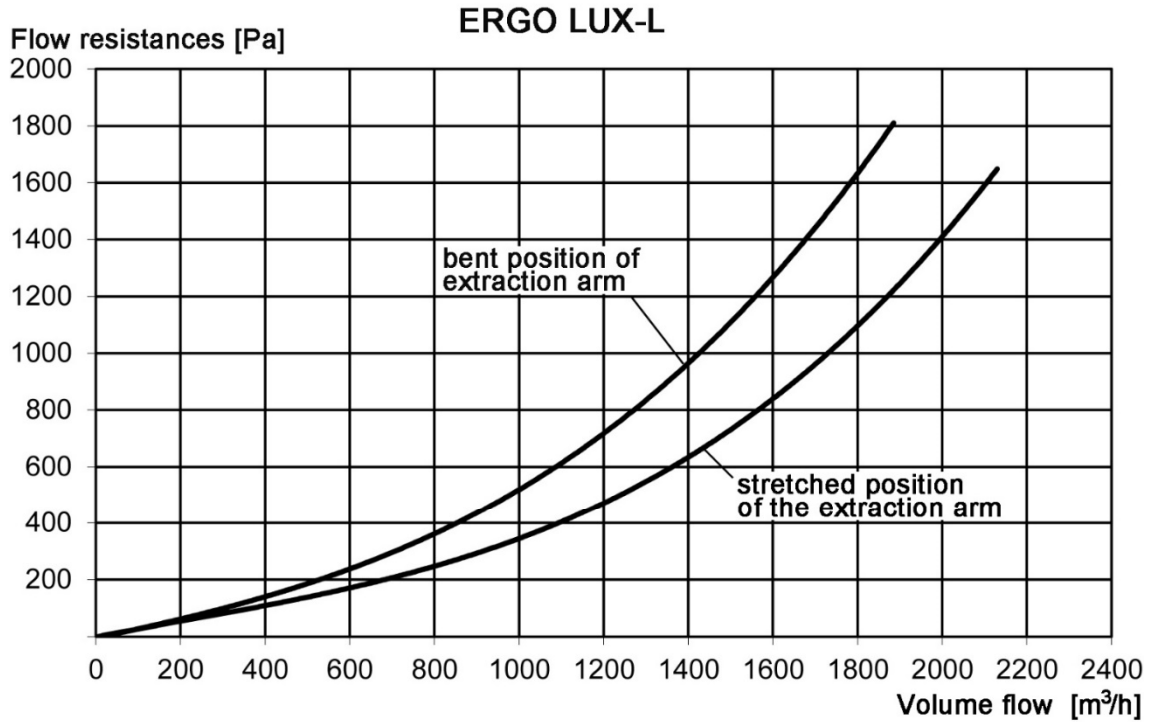

CAUTION: The bent position of the arm – angle 45° in the middle joint

5. STRUCTURE AND FUNCTION

The structure of the **ERGO LUX** extraction arms is illustrated in Fig. No.1.

They consist of subsequent elements:

- two arms (duct segments) connected with frictional joints,
- gas springs – to equilibrate the weight of the duct segments,
- plastic hood – with the inlet wire mesh – to protect the inlet from entering the glowing cigarette butts (embers) and spatters into the extraction arm,
- adjustment shut-off damper,
- swivel – with an integrated tight cut-off damper, as additional equipment.

The swivel guarantees full rotation of the whole extraction arm around its vertical axis and, additionally, provides easy device positioning at the requested point within the work area, during the use.

The swivel and the pipe segments, integrated with hose sections (flexible connectors), along with the hood and swivel form a ventilation ducting functioning for extraction of the dust-laden air. This suction duct configuration can be changed within the working range of the given type of extraction arm.

Frictional joints and gas springs provide the comfort of easy manoeuvring with the whole extraction arm. The suction hood can be equipped with a halogen spotlight that can be turned on using a switch on the hood. The lamp lights up the field of operation.

The extraction arm is installed on the wall or a supporting column, using a wall bracket. Moreover, it can also be suspended at the end of the **RO**-type extension arm (for the details see Use and Maintenance Manual “Extension arms **RO**” or adequate catalogue cards).

6. ASSEMBLY AND START-UP

Table No.6 – Diameters and mounting hole patterns in the swivel

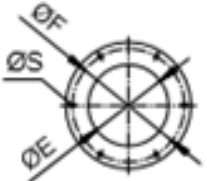
	E [mm]	F [mm]	S [mm]	Application
	~ ø110	ø165	6xø6,5	ERGO LUX-M/1,5; ERGO LUX-K/2; ERGO LUX-M/2; ERGO LUX-K/3
	~ ø160	ø194		ERGO LUX-L/2; ERGO LUX-L/4; ERGO LUX-L/3
	~ ø195	ø246	8xø8,5	ERGO LUX-D/2; ERGO LUX-D/4; ERGO LUX-D/3;

Extraction arms are delivered in cardboard packages, in a partly assembled state. Before the extraction arm is installed at the workplace – it is important to put the extraction arm together to form a completely assembled structure – according to the enclosed assembly instruction (see page 13 of the present Use and Maintenance Manual).

Wall brackets with which the extraction arms are attached are supplied separately. The diameter and distribution of the mounting holes in the bracket and the arms swivel are identical.

Do not install the **ERGO LUX** extraction arms directly to the ventilation ducting, because they are usually not constructed to carry such charges during the operational use of the device.

START-UP:

- Before work, start the extraction fan and make sure the ventilation discharge ductwork is functioning.
- Set the hood into a suitable position, not more than 30 cm from the welding arc, and not less than 20 cm – because the spatters might damage the hood and the suction stream could interrupt the protection gas shield (CO₂, argon).
- The position of the hood and the shut-off damper lever can be changed many times during the work, so the user can adjust the best to the current needs.
- After the work is completed – leave the extraction arm in the last used operational position when it does not cause an obstacle to personnel/traffic.
- Switch off the extraction fan (in the configuration when the arm cooperates with the extraction system, close the shut-off damper).

7. OPERATIONAL USE

The appliance does not require additional maintenance operations to work safely. Mainly, the adjustment of the **ERGO LUX** extraction arm consists of the settings within the frictional joints.

The frictional brakes are placed in each joint and their function is to provide the balance and self-supporting properties of the whole extraction arm and to guarantee easy manoeuvring during the operation.

The adjustment of the frictional brakes is carried out by increasing or reducing the tension of the nuts upon the frictional elements. The brake adjustment in the following joints ought to be executed in such a way that it guarantees the stability and self-supporting features of the extraction arm (which is important to keep the stable arm position). Whereas, on the other hand, do not tighten up too strongly, as this might affect excessive operational wear of the frictional elements and, subsequently the joints would get loose/released automatically.

The placement of the adjustment nuts is illustrated in Fig. No.1, whereas the frictional joint is shown in Fig. No.3.

Maximum allowable negative pressure in the ventilation system cannot exceed **800 Pa** for **ERGO LUX-M; -K; -L** arms and **1400 Pa** for **ERGO LUX-D** arms, otherwise the negative pressure may damage the hoses.

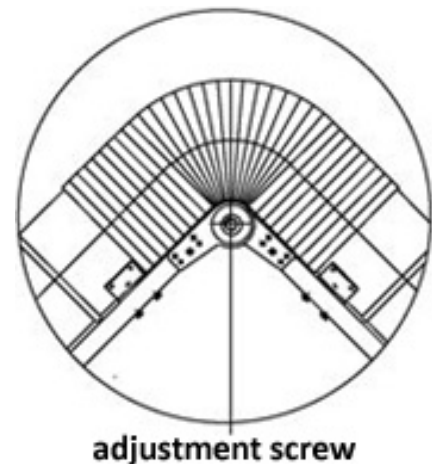

Fig. No.3 – Frictional joint

8. TROUBLESHOOTING GUIDE

	Problem	Possible reason	Corrective action
1.	The extraction arm falls.	Incorrectly adjusted frictional brake of the joint.	Increase the tension in joint frictional disks of the brake, within the joint by tightening the adjustment nuts.
2.	The extraction arm is automatically set in the same position.	The rotation axis of the extraction arm is not positioned vertically.	Carry out the positioning of the mounting flange of the extraction arm.
3.	Drop in the air suction rate along with the increased noise level of the extraction installation with the extraction arm.	Incorrect impeller rotation sense of the extraction fan.	Change the phase connection to the sequence of the three-phase motor.
		The protective wire mesh inlet grill is clogged.	Clean the wire-mesh inlet grill using a wire brush.

9. MAINTENANCE

Maintenance activities consist of the following steps:

- Periodically, clean the hood surface and the inlet wire mesh of the deposited dust and impurities to provide proper flow of the extracted air. In case of welding dust, rinse the hood additionally with the anti-spattering preparation (to avoid glueing up the welding chipping on the hood surface).
- Undertake the adjustment of its joint system in a case when the extraction arm loses its self-supporting properties.
- Lubricate the swivel every 3 months using solid grease (the lubrication nipple is located in the swivel flange).
- After 1 operational year, submit the device to technical revision and repair or replace the spotted faulty element.
- Clean the internal surfaces of the extraction segments from the deposited impurities. The frequency of these steps depends on the intensity of use. Within 3 months, it is recommended to examine the pollution state and undertake cleaning when necessary.

10. OCCUPATIONAL HEALTH AND SAFETY

Before starting and using, it is important to get acquainted with the present Use and Maintenance Manual.

The **ERGO LUX** extraction arms will not cause any hazard under the condition that they are firmly and correctly mounted to the wall or another structural element of the building.

Unsure mounting could result in an uncontrolled detachment of the device and would cause serious hazards to personnel/people in the vicinity.

Having completed the work, leave the extraction arm in the ultimate operational position, in the case when it constitutes an obstacle/barrier to personnel, set it into the home position.

Before installing check the load-carrying capacity of the building structure.

11. TRANSPORT AND STORAGE

Extraction arms ought to be stored and transported in a partly assembled state and special packages (designed for this purpose).

During the transport and reloading protect the device from damage, scratching, and indentations and pay attention that the markings would not get detached/obliterated. Store the extraction arms in dry rooms and areas of efficient ventilation.

12. TERMS OF WARRANTY

The period of warranty for the purchased device is indicated in the “Card of Warranty”. The warranty does not comprise:

- mechanical damage and dysfunctions caused by the User,
- device failures caused during use which was in contradiction with the purpose of operational use and the present Use and Maintenance Manual,
- damages being affected during improper transport, storage or incorrect maintenance.

Infringement of section 3 “Reservations of Producer” of the Use and Maintenance Manual and especially modifications undertaken by the User on one own shall result in the loss of warranty validity.

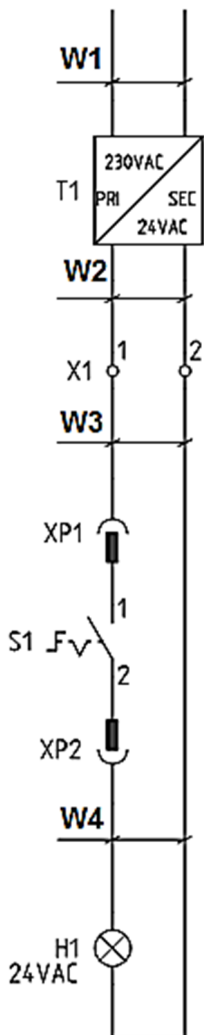

Fig. No.4 – Connection diagram of the halogen lamp

13. ASSEMBLY INSTRUCTION OF EXTRACTION ARMS

1. Take out the **ERGO LUX** extraction arm from the transport package and put it stably on an even surface.
2. Pull the arm segments apart to enable further assembly.
3. Screw up the swivel support, to the plate of the lower joint – according to the information in Fig. No.5 Detail "C".
4. Fold in the loose hose fabric edge (to even it up), at the end of the hose – then sleeve the hose onto the swivel ferrule and secure it with a hose clamp.
5. Screw together the terminations of the gas spring with a plate of the lower joint – according to Fig. No.6 Detail "A" (see also Photo No.1).
6. Connect segment II with segment I using a hose – according to information in Clause 4.
7. Screw up the element of the hood joint, with the pipe – according to the information in Fig. No.6, Detail "B".
8. Using a hose, connect segment II with the hood – according to the information in Clause 4.
9. Install the **ERGO LUX** extraction arm at a wall bracket or to a device (see Photo No.1).

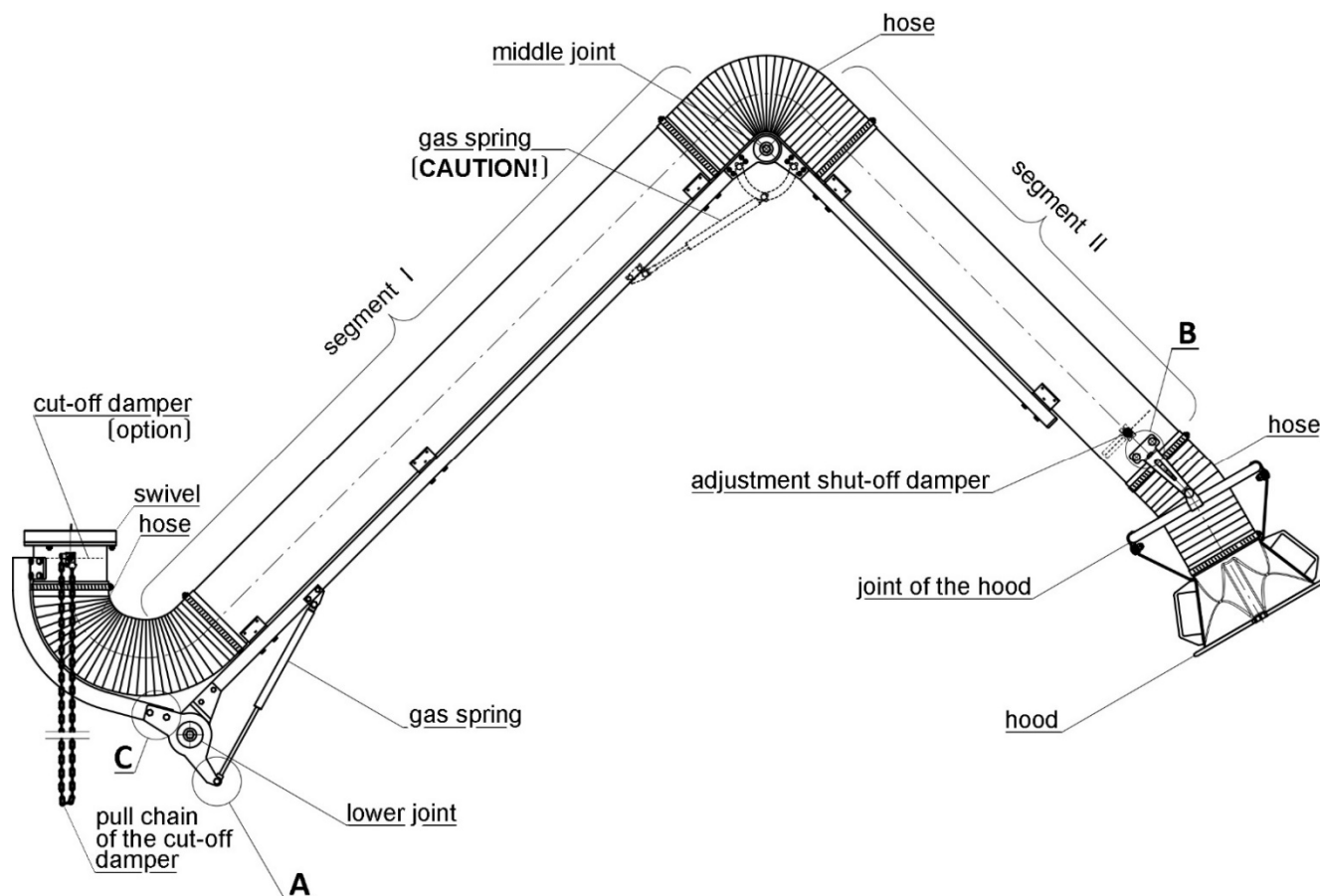

Fig. No.5

CAUTION:

For the **ERGO LUX-L/4**, **ERGO LUX-D/3** and **ERGO LUX-D/4** extraction arms, an additional gas spring is installed in the central joint.

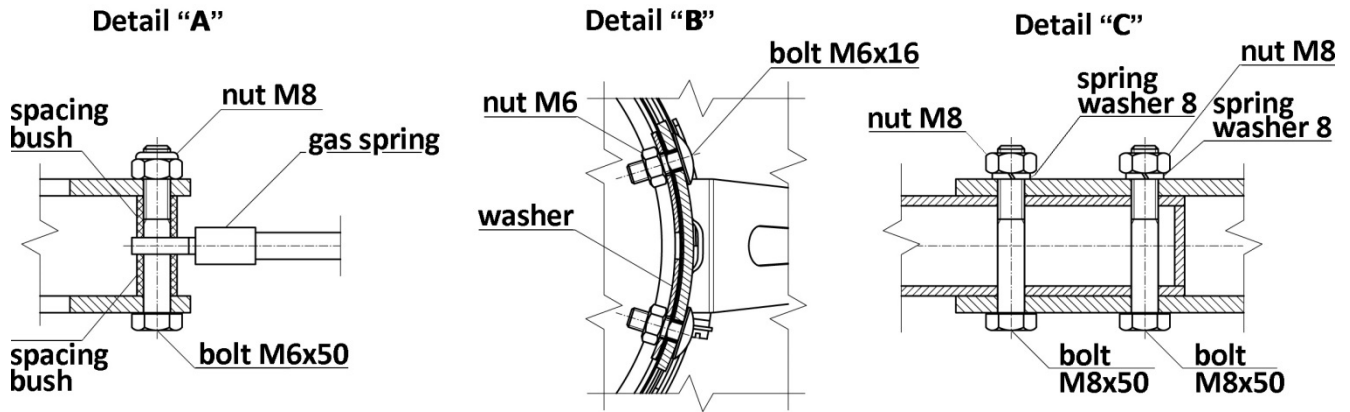

Fig. No.6 – Assembly instruction of the extraction arms type ERGO LUX-M;-K;-L;-D

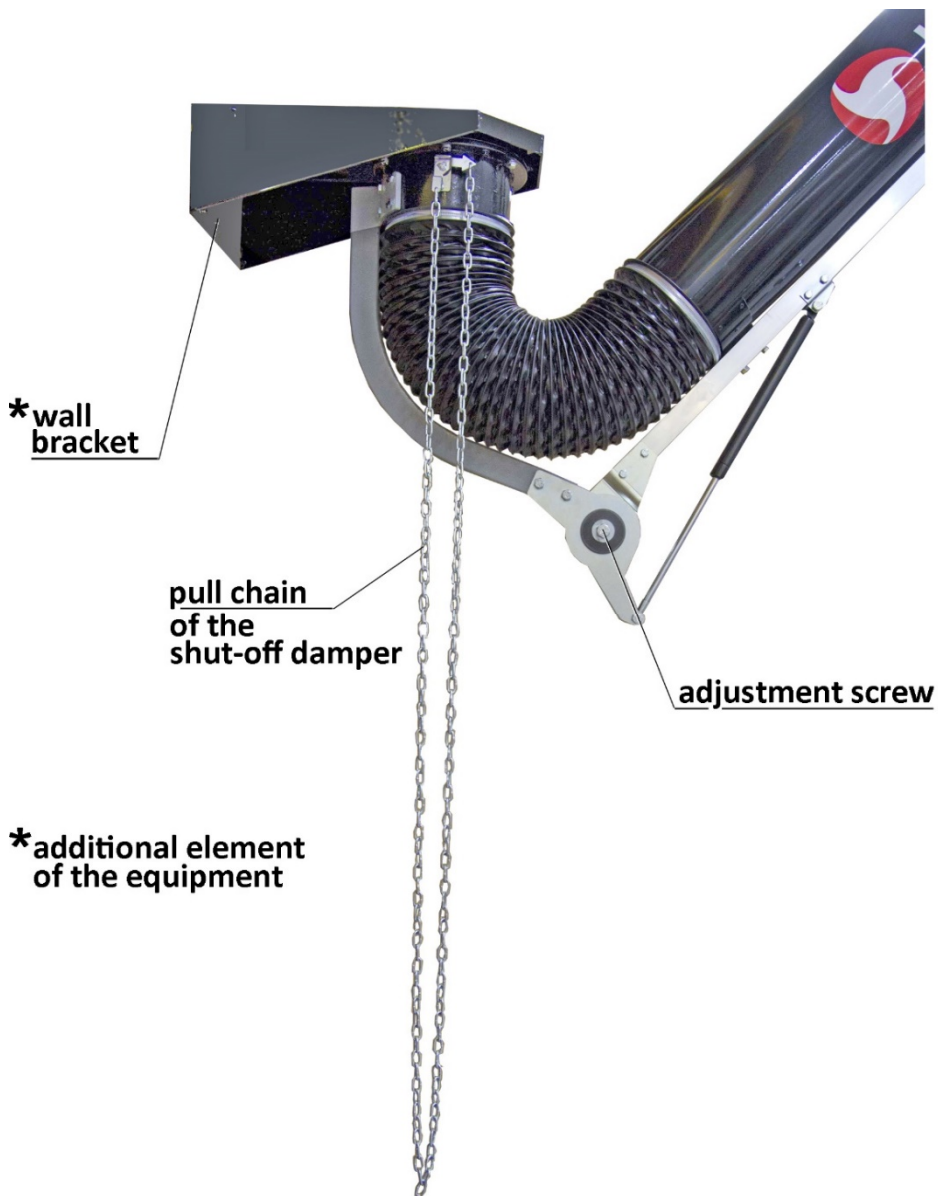

Photo No.1 – Wall bracket

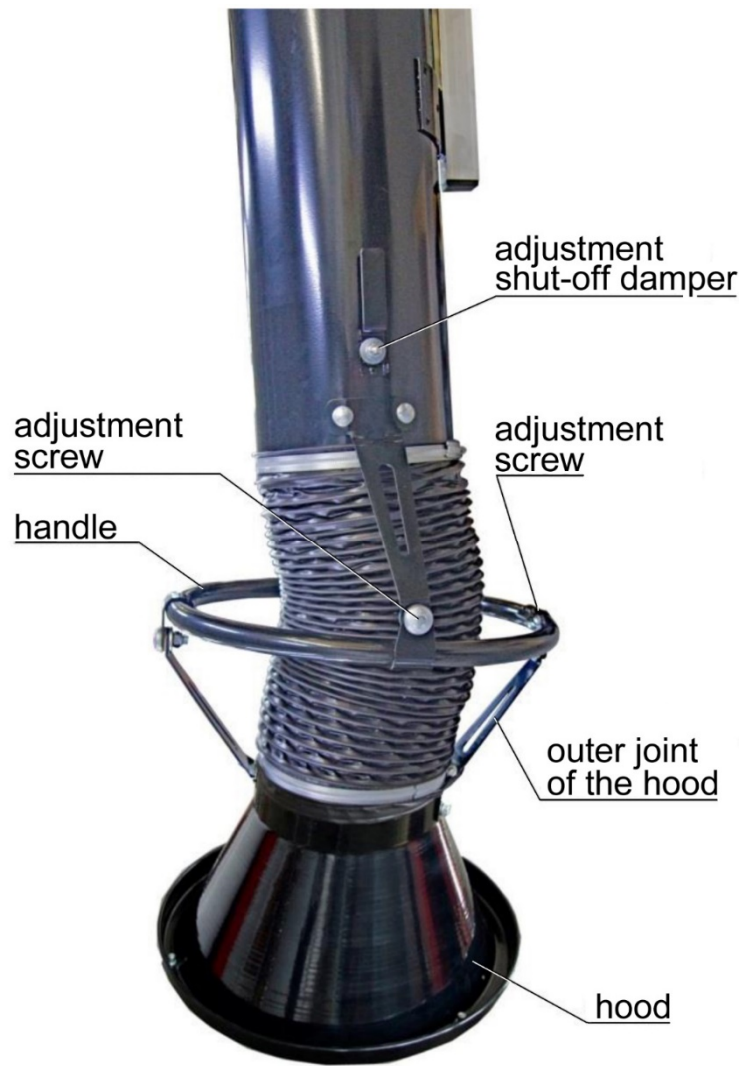

Photo No.2 – Hood

In case when the extraction arm is installed at the wall bracket, it is important to level the mounting plane of the wall bracket during its installation to the wall (see Photo No.1). If the bracket mounting plane is not horizontal, the extraction arm would tend to set (turn) itself always in the same position, and it is difficult to adjust the arm's position.

14. SAMPLE OF THE DECLARATION OF CONFORMITY

Declaration of conformity EC No.

Manufacturer (eventually the authorized representative/importer):

name: **KLIMAWENT S.A.**

address: **81-571 Gdynia, Chwaszczyńska 194, POLAND**

A person, authorized for issuing the technical documentation: **Teodor Świrbutowicz, KLIMAWENT S.A.**

Hereby declares that the appliance:

name: **Hanging Extraction Arm**

type/model: **ERGO LUX**

serial number: year of production:

Meets the requirements of the subsequent European Directives:

- **2006/42/EC Machinery Directive** of the European Parliament and of the Council of May 17th, 2006 on machinery – amending the 95/16/EC (recast) (Journal of Laws EC L157 of 09.06.2006, page 24)

The appliance meets the following harmonized standards:

- **EN ISO 12100:2012** – “Safety of machinery – Basic concepts, general principles for design. Risk assessment and risk reduction”.

.....
place, date

.....
signature of an authorised person

.....
name, surname, function
of the signatory

**Producer:****KLIMAWENT S.A.****81-571 Gdynia, ul. Chwaszczyńska 194****tel. 058 629 64 80****fax 058 629 64 19****e-mail: klimawent@klimawent.com.pl****www.klimawent.com.pl**

810R70 ERGO LUX-M-1,5
810R71 ERGO LUX-M-2
810R72 ERGO LUX-K-2
810R73 ERGO LUX-K-3
810R74 ERGO LUX-L-2
810R75 ERGO LUX-L-3
810R76 ERGO LUX-L-4
810R77 ERGO LUX-D-2
810R78 ERGO LUX-D-3
810R79 ERGO LUX-D-4
809R02 ERGO LUX-LL-2
809R03 ERGO LUX-LL-3
809R04 ERGO LUX-LL-4
809R05 ERGO LUX-DL-2
809R06 ERGO LUX-DL-3
809R07 ERGO LUX-DL-4