

UFO-A-N – devices with Venturi orifices



UFO-A-5000-N



UFO-A-10000-N

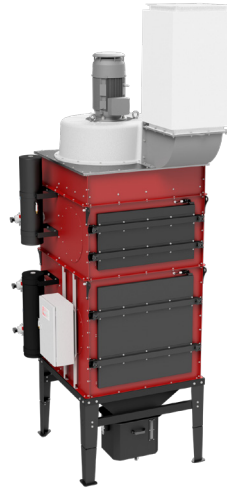

UFO-A-15000-N



UFO-A-20000-N

Purpose

UFO-A-N filtering units are designed for cleaning the dust-laden air from impurities arising during manufacturing processes. They are irreplaceable in elimination the dry dusts during the welding, grinding the non-sparking materials, gas- or plasma metal cutting, powder painting, cast iron processing and during other dust emitting processes in chemical industry, pharmaceuticals, food-, plastic industry and others. Maximum temperature of the conveyed air should not exceed +60°C. The appliances are equipped with cartridge filters accumulating the dust particles at the external surface of the filter, where the dust is struck off by impulses of compressed air.

Structure

The appliance consists of one or two filtration chambers and a fan located on the filtration fan. The filtration chamber is placed on a four-leg base with a hopper and a dust container.

UFO-A-5000-N and UFO-A-10000-N consists of one filtration chamber and a fan of nominal volume flows 5000 and 10 000 m³/h respectively.

UFO-A-15000-N and UFO-A-20000-N consists of two filtration chambers and a fan of nominal volume flows 15 000 and 20 000 m³/h respectively.

Each filtration chamber is separated inside with a vertical wall, creating two areas:

- chamber of filters – containing the self-cleaning cartridge filters with coated polyester fabric, of filtration efficiency up to 99,9%,
- cleaning chamber – containing the Venturi orifices, to clean the cartridge filters from the accumulated dust by means of the compressed air impulses. The cleaning / shaking proceeds automatically.

Outside of the filtration chamber is located a compressed air tank with electromagnetic valves, connected to the external compressed air installation of 6–8 bar pressure. Above the filtration chamber is installed a decompression chamber and extraction fan in aluminium housing.

At the inlet side, UFO-A-N is equipped with Ø500 mm connection fitting piece, on each filtration chamber. As standard, the connections are located on the right side of the device, (view-

ing onto the filtration chamber side). It is possible to execute a device version with its inlet on the left side. The appliance is integrated with an automation system to control the power supply of the fan and the system of the pneumatic filter regeneration system.

Operational use

It is possible to install the UFO-A-N system inside the process rooms or as outdoor application. Prior to use it is important to fasten firmly the device to the floor.

The appliance is designed for:

- operation with a system of local exhausts, e. g. extraction arms, connected to the main collecting ductwork attached to its inlets,
- general ventilation, combined with air filtration, e. g. operation within the push-pull system.

After the system is started, the automation control unit provides continuous work of the extraction fan, and the automatic filters regeneration with the impulses of compressed air. The cartridge filters ought to be replaced for new after 1–2 years of operational use.

REMARKS:

1. In case of plasma cutting application, take into account the fact that the real flow efficiency of the device is two times lower than the nominal efficiency.
1. For example: UFO-A-10000-N with its volume flow 10 000 m³/h provides 5000 m³/h during the plasma cutting, whereby this is sufficient for extraction from one table segment: 2100 x 500 mm.
2. On demand, the cartridge filters can be equipped with activated carbon activated fabric, for filtration of gaseous contamination during the welding.
3. UFO-A-N can be additionally equipped with an inverter to control the motor function. Due to this, it is possible to adjust the motor rotational speed to the efficiency of the device, at the constant vacuum within the extraction ductwork.

Additional equipment

1. spark catcher,
2. dust spraying unit.

UFO-A-N

Technical data

Type	UFO-A-5000-N	UFO-A-10000-N	UFO-A-15000-N	UFO-A-20000-N
Part No.	805U20	805U21	805U22	805U23
Maximum volume flow [m ³ /h]	7500	13 000	18 000	24 000
Operational volume flow [m ³ /h]	4000-5000	8000-10 000	12 000-15 000	16 000-20 000
Maximum vacuum [Pa]	3900	4500	5100	5000
Motor rate [kW]	5,5	11	18,5	22
Filtration surface [m ²]	60	120	180	240
Supply voltage [V]	3x400	3x400	3x400	3x400
Acoustic pressure level [dB(A)] ¹	72	76	78	80
Weight [kg] ²	575	765	1015	1125
Quantity of inlet connections [szt.]	1x500	1x500	2x500	2x500
Required compressed air pressure [bar]	6-8			
Quantity of cartridge filters	2	4	6	8
Capacity of the dust container [dm ³]	72	72	72	72
Minimum compressed air consumption [Nm ³ /h]	2,8	5,6	5,6	11,2

1. Measuring has been carried out from distance 1 metre, at the device at its nominal volume flow.
2. Weight of the device without silencers.

Flow charts

UFO-A-5000-N

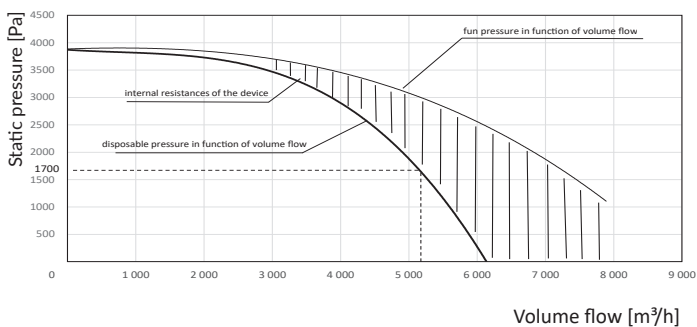

UFO-A-10000-N

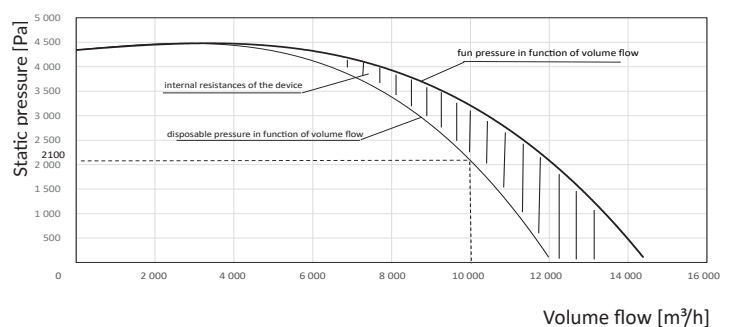

UFO-A-15000-N

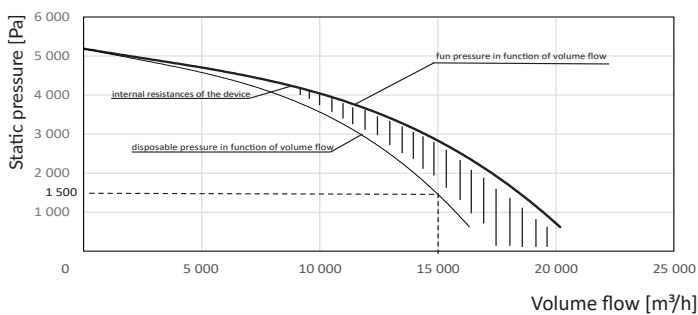

UFO-A-20000-N

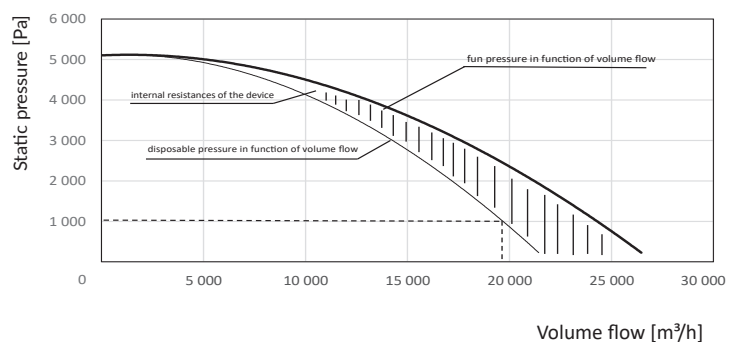

Remark: Flow charts has been prepared for cartridge filters initially polluted with dust after using 1500 electrodes ER24.

UFO-A-N

UFO-A-5000-N

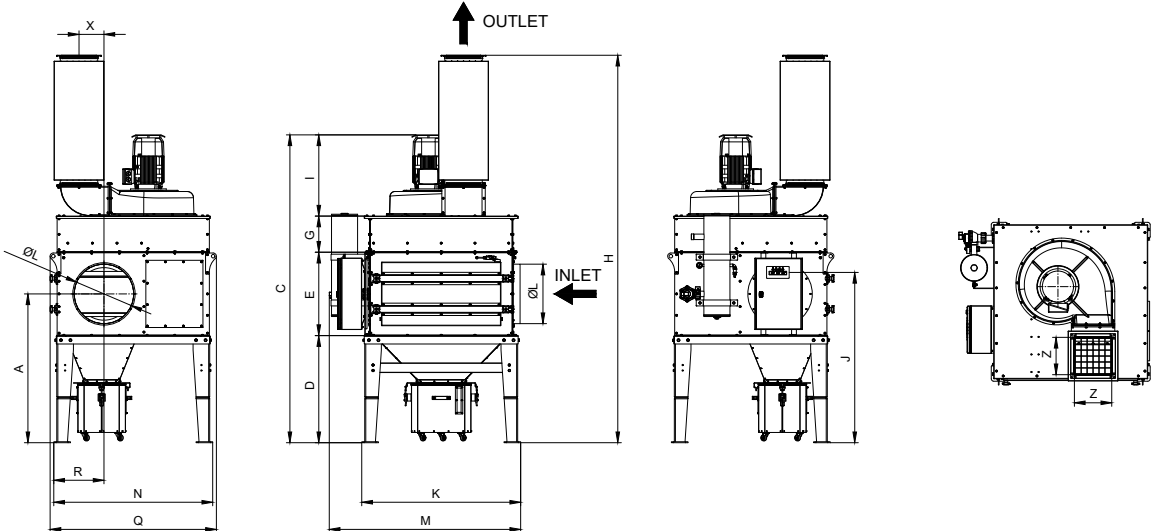

UFO-A-10000-N

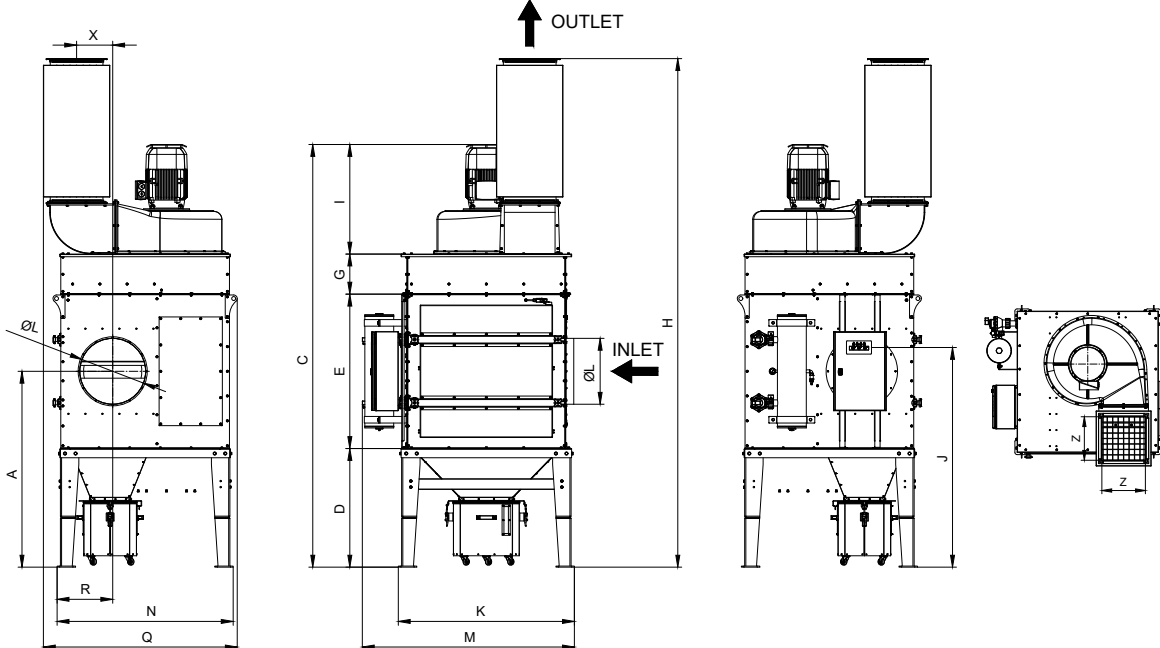

UFO-A-15000-N

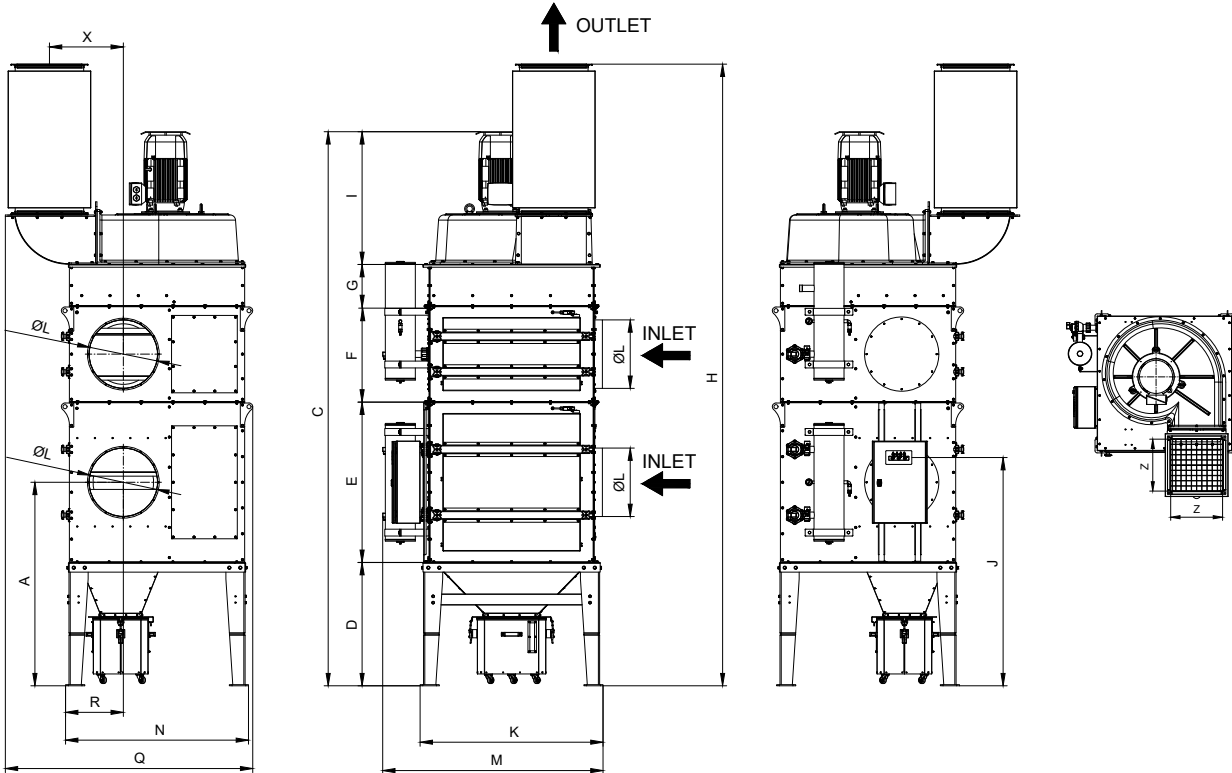

UFO-A-N

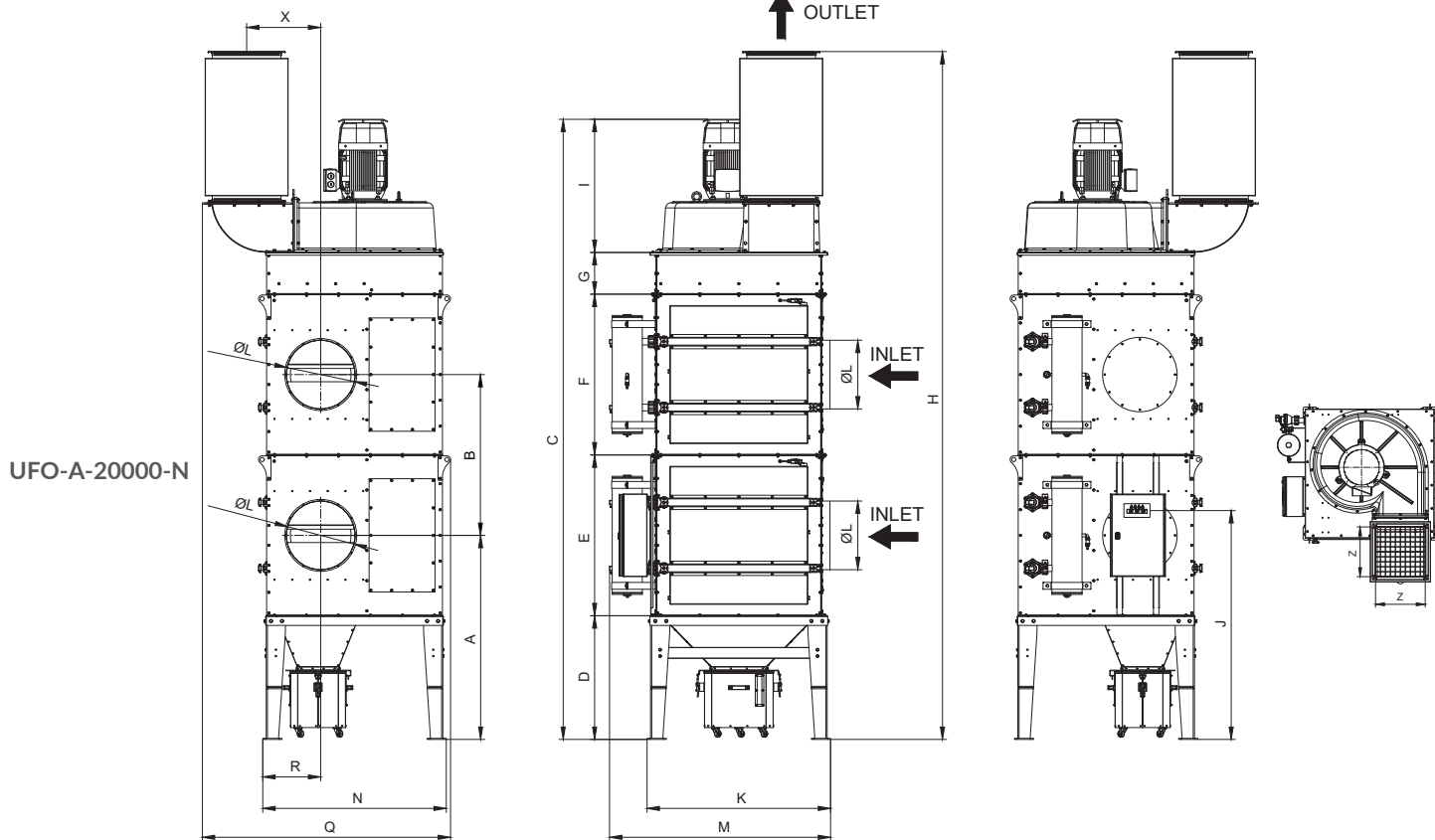

Dimensions

Type	A [mm]	B [mm]	C [mm]	D [mm]	E [mm]	F [mm]	G [mm]	H [mm]	I [mm]	J [mm]	K [mm]	ØL [mm]	M [mm]	N [mm]	R [mm]	Q [mm]	X [mm]	Z [mm]
UFO-A-5000-N	1250	-	2590	900	700	-	305	3260	680	1430	1335	500	1610	1335	420	1400	210	315
UFO-A-10000-N	1485	-	3205	900	1170	-	305	3860	830	1665	1335	500	1610	1335	420	1470	275	400
UFO-A-15000-N	1485	-	4045	900	1170	700	305	4540	970	1665	1335	500	1610	1335	420	1805	540	500
UFO-A-20000-N	1485	1170	4515	900	1170	1170	305	5010	970	1665	1335	500	1610	1335	420	1805	540	500

Replaceable parts

Cartridge filter

	Type	Part No.	Weight [kg]	Filtration efficiency [%]	Filtration surface [m ²]
	PN306638U	800F25	4,2	up to 99,9	30

Additional equipment

Spark catcher

	Type	Part No.	Connection diameter [mm]	Weight [kg]	Remarks
	D-500	840Ł03	500	55	Spark catcher should be installed at the inlet connection of the UFO-A-N device or within the extraction ductwork. This eliminates the sparks or other glowing particles/embers that might be conveyed along with discharged dust, to protect the filtering unit from fire hazard. It is important to clean the spark catcher net.

Dust spraying unit

	Type	Part No.	Remarks
	UN-1	804U20	UN-1 dust spraying unit dispenses the CaCO ₃ (from the container) into the extraction ductwork. The created air-CaCO ₃ mixture protects the filters from excessive pollution deposits, increases their longevity and reduces the hazard of ignition/fire.