

WPA-BOX – fan chamber

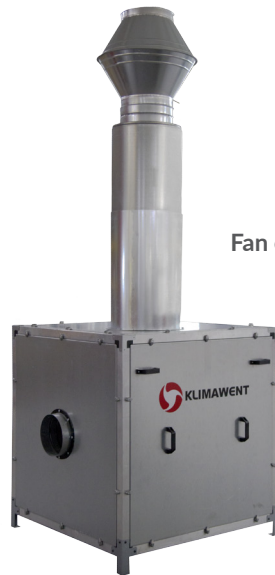

Fan chamber with a silencer and air discharge at the outlet

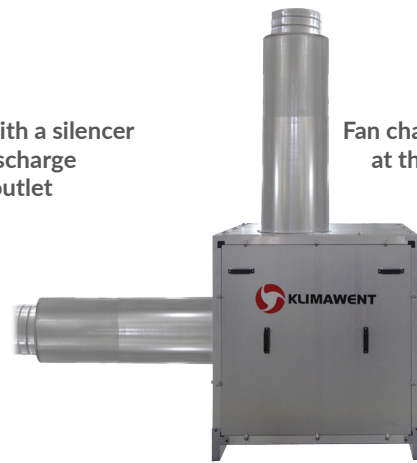

Fan chamber with silencers at the inlet and outlet

Purpose

WPA-BOX fan chambers are meant for use within the installations of mechanical air-supply ventilation or extraction installations of rooms and workplaces, where particularly silent work is required. Chambers can be applied with filtering units. They are designed for application inside the buildings. The fans applied in the chambers meet the requirements of ErP 2009/125/EC Directive.

Structure

The chambers are constructed of aluminium profile frame. Within the frames are installed panels with sound-absorbing pads. Inside the chamber is located a fan. The fan consists of a steel spiral housing and a motor. The aluminium radial impeller is directly installed on the motor shaft, whereby the impeller blades cross-section is similar to the aircraft wing profile, providing low acoustic pressure level.

For safety reason, the inlet and outlet are equipped with protective grills. The fan motor is mounted on a base which is placed on a vibro-absorbing frame, to avoid vibration transmission to the floor. As option, the chamber inlet (and/or chamber outlet) can be fitted with a sound damping set, to reduce further the noise. On demand of Customer, we deliver safety switches to disconnect the supply during the installing and servicing activities (see catalogue card ELECTRICAL ACCESSORIES).

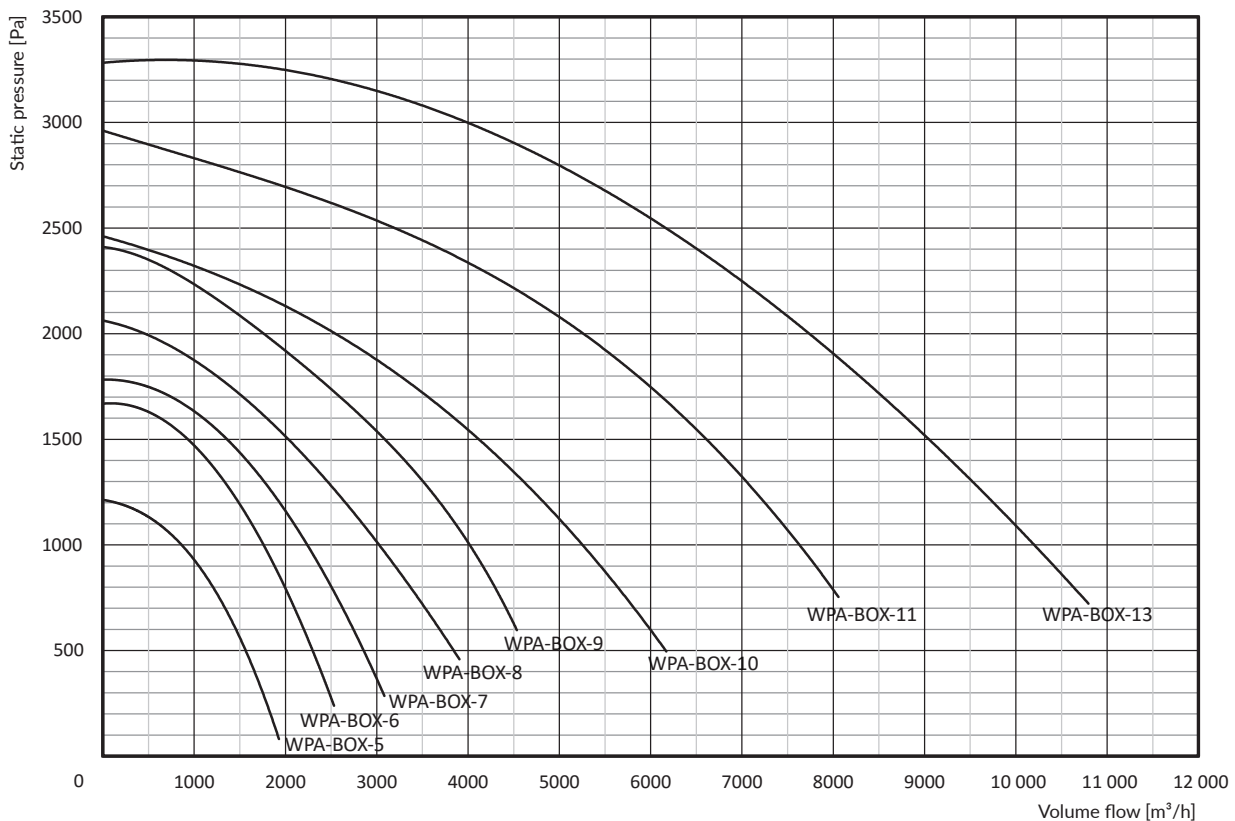

WPA-BOX

Technical data

Type	Part no.	Synchronous rotations [1/min]	Supply voltage [V]	Motor rate [kW]	Ingress protection IP	Acoustic pressure level [dB(A)] from a distance of*:		Maximum volume flow [m³/h]	Maximum vacuum [Pa]	Weight [kg]
						1 m	5 m			
WPA-BOX-5-1	814K31	3000	230	0,55	54	54	40	1900	1250	130
WPA-BOX-5-3	814K32	3000	3x400	0,55	54	54	40	1900	1250	130
WPA-BOX-6-1	814K33	3000	230	0,75	54	61	47	2500	1700	135
WPA-BOX-6-3	814K34	3000	3x400	0,75	54	61	47	2500	1700	135
WPA-BOX-7-1	814K35	3000	230	1,1	54	64	50	3100	1800	137
WPA-BOX-7-3	814K36	3000	3x400	1,1	54	64	50	3100	1800	137
WPA-BOX-8-3	814K37	3000	3x400	1,5	54	66	52	3900	2050	196
WPA-BOX-9-3	814K38	3000	3x400	2,2	54	69	55	4500	2400	204
WPA-BOX-10-3	814K39	3000	3x400	3,0	54	69	55	6200	2450	282
WPA-BOX-11-3	814K40	3000	3x400	5,5	54	75	61	8050	2950	298
WPA-BOX-13-3	814K41	3000	3x400	7,5	54	77	63	10 800	3300	318

* Acoustic pressure level of the housing was measured in the installation with silencers type T-WPA-BOX at the inlet and outlet of the fan chamber.

1. Maximum temperature of the conveyed air is +60°C. Maximum temperature in the work area +40°C.

2. Maximum dustiness of the conveyed air should not exceed 0,3 g/m³.

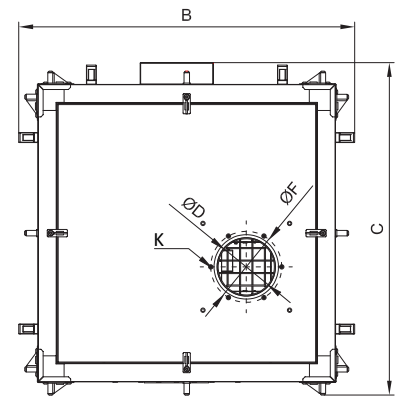
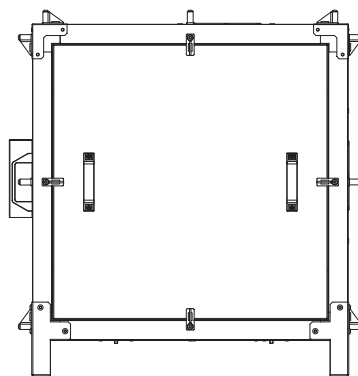
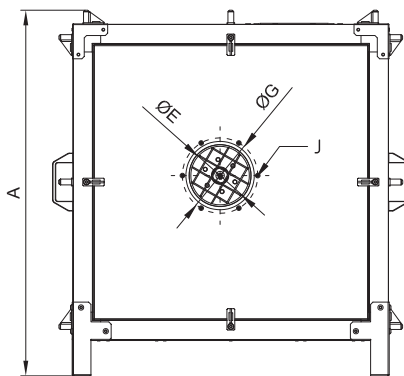

Top view of the chamber

Dimensions

Type	A [mm]	B [mm]	C [mm]	Diameters of connections		Pitch diameter of the connection holes		K [mm]	J [mm]
				ØD [mm]	ØE [mm]	ØF [mm]	ØG [mm]		
WPA-BOX-5	941	918	908	160	160	194	194	M6	M6
WPA-BOX-6	941	918	908	160	160	194	194	M6	M6
WPA-BOX-7	941	918	908	200	200	224	224	M8	M6
WPA-BOX-8	1121	1098	1108	200	200	224	224	M8	M8
WPA-BOX-9	1121	1098	1108	200	200	224	224	M8	M8
WPA-BOX-10	1329	1336	1336	250	250	274	274	M8	M8
WPA-BOX-11	1329	1336	1336	250	250	274	274	M8	M8
WPA-BOX-13	1329	1336	1336	315	315	344	344	M8	M8

Additional accessories

Silencer

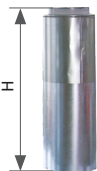
	Type	Part no.	Inlet [mm]	Outlet [mm]	Height H [mm]	Cooperating fan chambers	Remarks
	T-200 WPA-BOX	830T26	160	200	1250	5, 6	The set consists of: reducer, silencer, silencer bracket. Install the set on the inlet ferrule or on the outlet of the WPA-BOX fan chamber.
	T-250 WPA-BOX	830T27	200	250	1250	7, 8, 9	
	T-315 WPA-BOX	830T28	250	315	1250	10, 11	
	T-400 WPA-BOX	830T29	315	400	1300	13	

Air discharge

	Type	Part no.	Diameter inlet/outlet/height [mm]	Weight [kg]
	E-200	842W37	200/200/500	6
	E-250	842W38	250/250/600	10
	E-315	842W39	315/315/700	14
	E-400	842W40	400/400/900	18