

USE AND MAINTENANCE MANUAL



Filtering unit **BIG-10000/Ex** (XCC-109)

ATEX marking:  II 3 D Ex tD A22 T200°C

Contents:

1. INTRODUCTION	2
2. PURPOSE	2
3. RESERVATIONS OF MANUFACTURER	3
4. TECHNICAL DATA	3
5. STRUCTURE AND FUNCTION	4
6. ASSEMBLY AND STARTUP	6
7. OPERATIONAL USE	8
8. TROUBLESHOOTING GUIDE	15
9. MAINTENANCE AND REPAIR	15
10. OCCUPATIONAL HEALTH AND SAFETY	16
11. TRANSPORT AND STORAGE	16
12. TERMS OF WARRANTY	16
13. DECLARATION OF CONFORMITY	17

Producer: **KLIMAWENT S.A.**
 81-571 Gdynia, ul. Chwaszczyńska 194
 tel. 58 629 64 80, 58 771 43 40
 fax 58 629 64 19
 email: klimawent@klimawent.com.pl



1. INTRODUCTION

The purpose of the present Use and Maintenance Manual is to supply User with directions within the range of application, assembly, start-up and operational use of the **BIG-10000/Ex** Filtering unit.



Prior to assembly at the place of operation and use, it is important to get thoroughly acquainted with the contents of the present instruction.



With regard to continuity of work carried on improvement of our products, we reserve for ourselves the revision possibility of the draft and technological changes improving their functional features and safety.

Construction of **BIG-10000/Ex** meets the requirements of the current state of technology as well as the safety and health assurances included in:

the safety and health assurances included in:

2006/42/EC Directive of the European Parliament and of the Council of the 17 May, 2006 on machinery, amending the 95/16/EC Directive (recast) / Official Journal EC L157 of the 09.06.2006, page 24);

2014/35/EC Directive of the European Parliament and of the Council of the 26 February, 2014 on the harmonisation of the laws of the Member States, relating to the making available on the market of electrical equipment designed for use within certain voltage limits / Official Journal EC L96 of the 29.03.2014;

2014/34/EC Directive of the European Parliament and of the Council of the 26 February, 2014 on the harmonisation of the laws of the Member States, relating to the equipment and protective systems intended for use in potentially explosive atmospheres / Official Journal EC L96 of the 29.03.2014 /

1999/92/EC Directive of the Council of the 19 December, 1999 on minimum requirements regarding safety of health protection of workers employed at workplaces where explosive atmosphere is likely to occur / Official Journal No.138, Pos. 931/

Is in accordance with the subsequent harmonised standards:

EN ISO-12100:2012 Safety of machinery – General principles of design – Assessment and reduction of hazard

EN 60204-1:2018-12 Safety of machinery – Electrical equipment of machines – Part 1: General requirements

EN ISO 13857:2010 Safety of machinery – Safe distances to prevent hazard zones from being reached by upper and lower limbs

EN 60079-0:2013-03/A11:2014-03 Electrical appliances in areas of gas explosion hazard – Part 0: General requirements

EN 1127-1:2011 Explosive atmospheres – Explosion prevention and protection. Basic terminology and methodology

EN ISO 80079-36:2016-07 Explosive atmospheres – Part 36: Non-electrical appliances in areas of explosion risk Methodology and requirements

2. PURPOSE

BIG-10000/Ex is appropriate for cleaning the dust laden air from **dry** dust particles, arising during production processes with occurrence of powdery materials and dust particles of ST1 explosiveness class. The appliance is equipped with 9 cartridge filters, with antistatic polyester membrane – functioning on the basis of surface filtration. Admissible maximum temperature of the filtered air is 40°C.

The device can be applied for such processes as:

- grinding of non-sparking materials,
- sand blasting, shot peening,
- mechanical cutting of metals, gas-, plasma-, laser-, arc cutting of metals,
- polishing, planishing,
- processing of plastics,
- metalization,
- powder varnishing.

Basic advantages of the device are optimum filtration efficiency, long operational use (longevity) of the cartridge filters, low power consumption and simple and fast maintenance. The appliance is admitted for use, according to the Ex marking, for cleaning the air in areas of explosion hazard, according to the ATEX 137 1999/92/EC Directive.

According to ATEX, the operational conditions are specified (as for this device) as follows:

Ex II 3 D Ex tD A22 T200°C. The subsequent markings are interpreted as:

- **group II** – the device is designed for work in enterprises, in on-ground premises, in sites of occurrence of explosion atmospheres, except for application in areas of methane hazard (firedamp), or risk connected with carbon dust;
- **category 3** – the device is designed for application in areas where explosive atmospheres are likely to occur, whereby the explosive atmospheres are of low risk;
- **D hazard** – flammable dusts;
- **Ex tD A22 IP65** – application of the implemented motor – as constructed and tested according to the European standards for application in areas of explosion hazard, with dust-proof housing and with the implemented protection against humidity.
- **T200°C** – the surface temperature of any part (of the device) will not exceed 200°C during normal operation.

BIG-10000-Ex filtering unit can be installed, exclusively in areas classified as 22, or in areas not featuring explosive hazard. According to the ATEX 137 Directive, User has to determine the environment where the appliance shall be used.

3. RESERVATIONS OF MANUFACTURER

3.1 Manufacturer is not responsible for damages / malfunctions being caused as a result of reasons mentioned below:

- Any consequences following from the installing that is in contradiction to the present Use and Maintenance Manual.
- Situations where the appliance is connected to the electrical power supply- or the pneumatic system incorrectly.
- Operational use that is in contradiction with the present Use and Maintenance Manual and its specified purpose.
- Installing of any additional elements that are not belonging to the normal device structure (or accessory set) is not acceptable.
- Introduction of any structural or constructional modifications of the system on one's own.
- Situations when the principles of control and maintenance of the appliance are not observed.
- Forwarding of the air containing viscous and aggressive impurities or of the air temperature exceeds 40°C what might result in damage of the filters.

3.2 In the course of operational use, it is important to prevent ignition sources (i.e. sparks, cigarette butts / embers) from getting into the filtering unit.

3.3 Operator should wear antistatic clothes while emptying the waste container, during the technical inspection, maintenance and during any other activities near the filtering unit.

3.4 Do not use mobile phones and devices emitting electromagnetic waves close to the filtering unit and in the vicinity.

3.5 At the side of decompression panel – it is important to create a hazard area of potential explosion according to the Fig. No.6. This area should be free of barriers such as machines, devices, walls etc.

3.6 In case when explosion hazard exists within the whole installation, (where the filtering unit is installed), User should carry out the total risk evaluation, with reference to the being valid regulations and should apply protections of the filtering unit and the fan.

4. TECHNICAL DATA

Table No.1

Type	Maximum volume flow	Maximum vacuum	Motor rate	Supply voltage	Quantity of cartridge filters	Acoustic pressure level	Compressed air consumption	Weight
	[m ³ /h]	[Pa]	[kW]	[V/Hz]	[pcs]	[dB(A)]	[Nm ³ /h]	[kg]
BIG-10000/Ex	17000	3300	11	3x400/50	9	74	7,2	1230

Filtration efficiency 99,9% (according to the BIA classification) the filters carry the USGC class certificate

Cartridge filters: quantity 9 pieces;
diameter Ø325 mm
height 1200 mm
total filtration area 87 m²

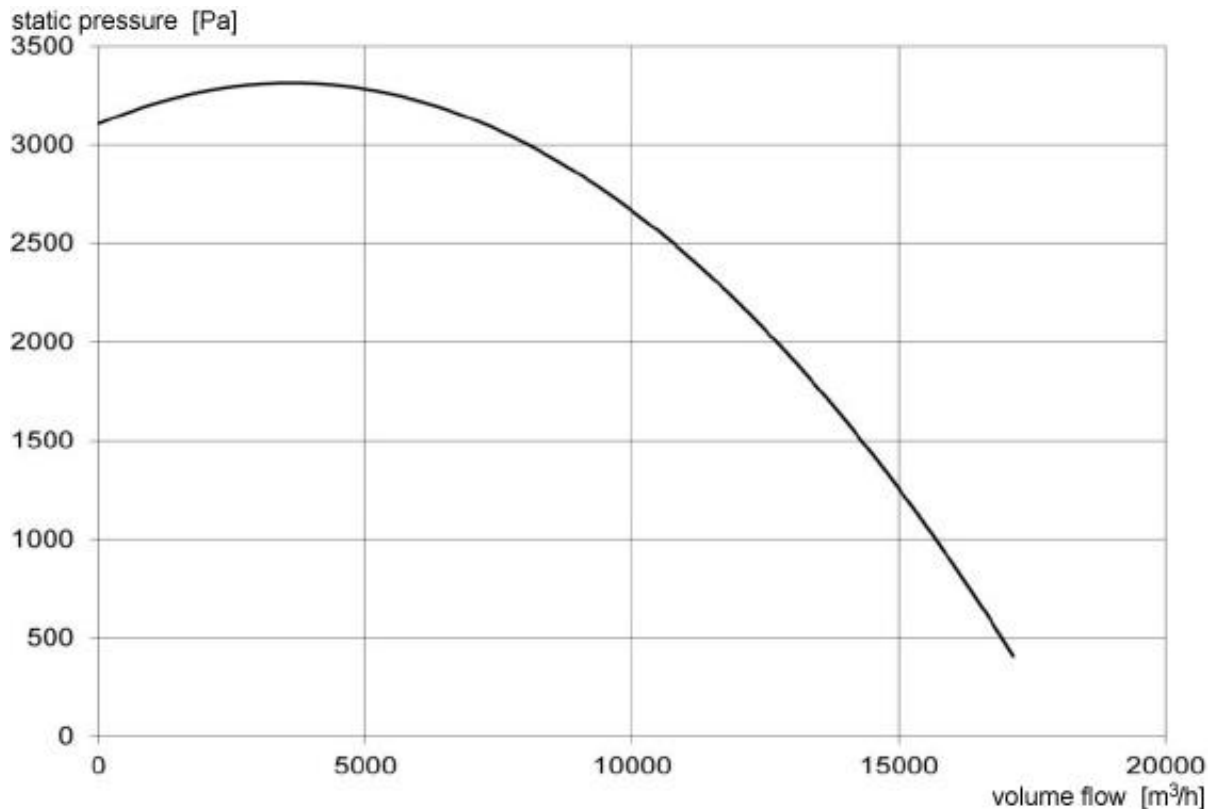

Fig. No.1 – BIG-10000/Ex – Flow chart

CAUTION: Measurement performed with the inlet connection attached to the filtering unit

According to the 99/92/EC ATEX 137 Directive, manufacturer carried out the classification of the internal and external zones, connected with the explosion hazard during the operation of the filtering unit.

In the **Fig. No.2** is presented the classification of the internal zones. The chamber of filters and the hopper chamber along with the waste container have been specified as **zone 20/21**, because in these areas always and in long periods potentially explosive atmosphere occurs.

Whereas, the regeneration chamber is classified as **zone 22**, because the dust occurs in this area sporadically, in case of failures consisting in damage of the cartridge filter or the filter mounting.

External zones can be created:

- while opening the inspection doors,
- during the emptying the waste container.

They have been classified as **zone 22**.

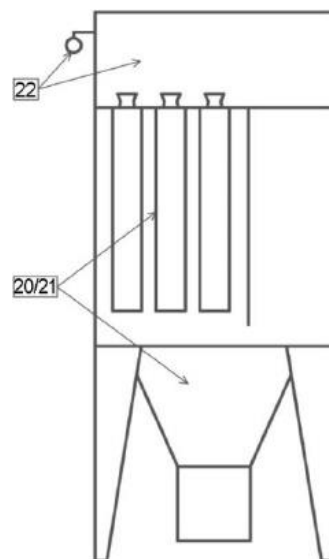

Fig. No.2 – Classification ATEX – internal zones

5. STRUCTURE AND FUNCTION

5.1 Structure

BIG-10000/Ex filtering unit consists of three functional assemblies:

- Regeneration chamber, being the upper part of the device, where are located outlets from the cartridge filters and Venturi Orifices. Outside the regeneration chamber is installed the compressed air installation, consisting of:
 - compressed air tank – constructed for operational pressure not exceeding 0,8 MPa, the tank meets the requirements of the **European Union Directive 87/404/EEG** and **90/488/EEG**;
 - three electromagnetic valves of diameter 1 1/2", designed for regeneration of the cartridge filters, these valves meet the requirements of directives: **ATEX 94/9/EC** and **EMC 89/336/EC**.
- Chamber of filters – forms the middle part of the filtering unit and contains the cartridge filters. On the chamber housing is located the inspection door, (for filter replacement) and a decompression panel lowering the pressure in case of potential explosion. Outside the chamber is installed a micro-controller – to activate the electromagnetic valves, (described in details in Section 7).
- Supporting construction along with the hopper chamber. Underneath the hopper chamber is placed a waste container.

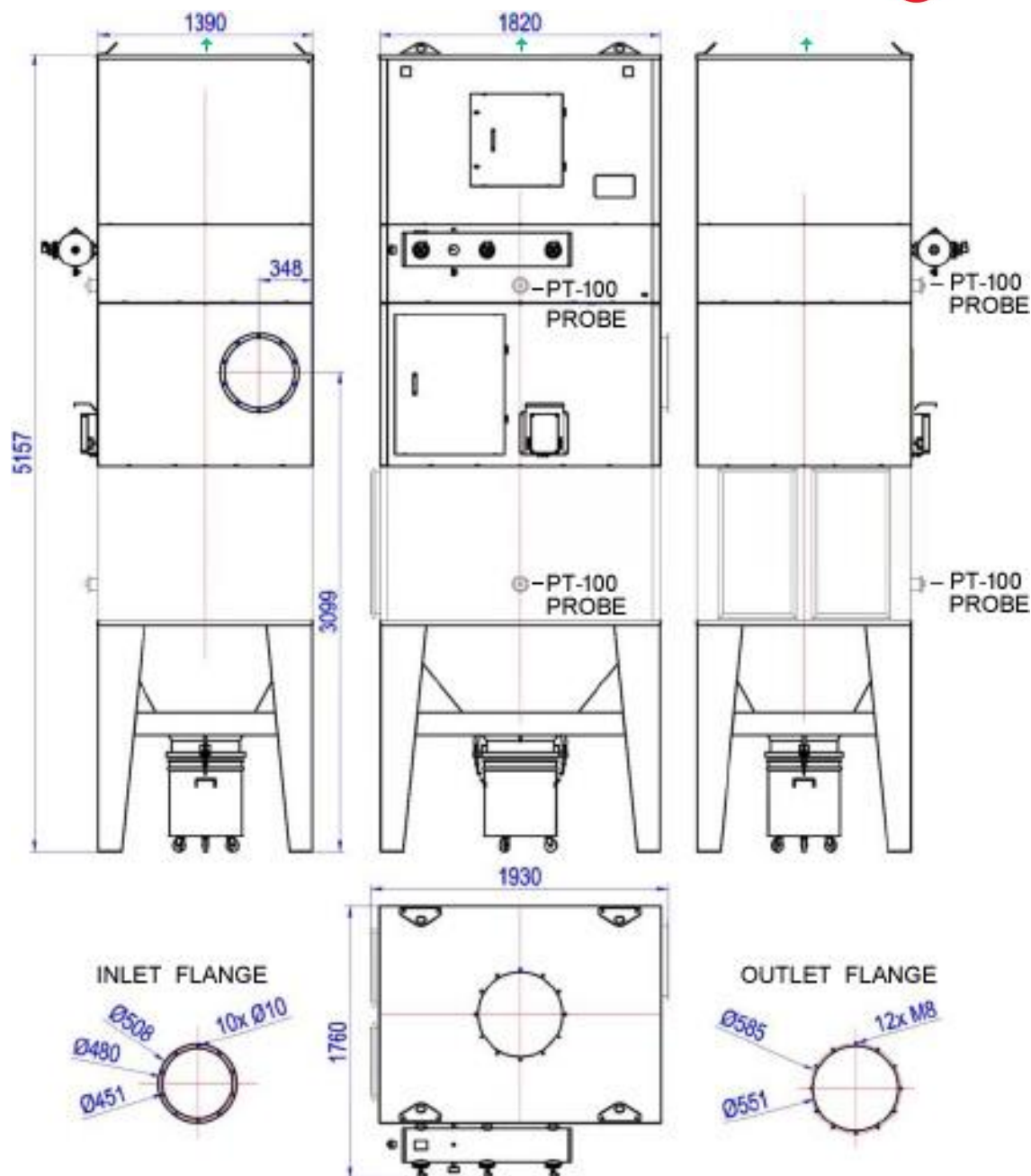

Fig. No.3 – BIG-10000/Ex – Structure and dimensions

BIG-10000/Ex filtering unit is served by an Ex execution fan, in a fan chamber. The fan chamber is located beyond the device and connected with it by a rigid spiral-seam duct of diameter $\varnothing 315$ mm. The applied fan is type GR 400/2 with a 11 kW motor – all this is integrated in the fan chamber of total weight 300 kg, as in details described in separate Use and Maintenance Manual. In Fig. No.3 is illustrated the filtering unit along with the fan chamber. Connection between these two units is an example as applied in the test station at the manufacturer.

To control the devices is applied a switchgear, which should be installed outside (beyond) the zone of explosion hazard. Detailed description can be found in Section 7 of the present Use and Maintenance Manual.
CAUTION: The switchgear, fan along with the fan chamber are delivered upon separate order.

5.2 Function

BIG-10000/Ex filtering unit provides separation of the air containing **dry** dust fraction. The dust laden air is guided to the chamber of filters. Here, in the decompression process and because of the flow velocity reduction, larger particles of dust are extracted into the hopper chamber, and subsequently they fall into the waste container. Precise dust cleaning proceeds while the air flows through the cartridge filters. In the Fig. No.4 is presented a run diagram of the air flow through the filtering unit. As the dust accumulates on the operational surface of the cartridge filters, this reduces the air flow intensity. To limit this disturbance, the device is equipped with a continuous regeneration system of the filters. The impulses of compressed air (directed into the cartridge filters) strike off the dust particles. The cleaning air is supplied from the compressed air tank, through the electromagnetic valves that are operated by the micro-controller (as in details described in Section No.7).

In the Fig. No.5 is illustrated a schematic diagram of regeneration of the cartridge filters.

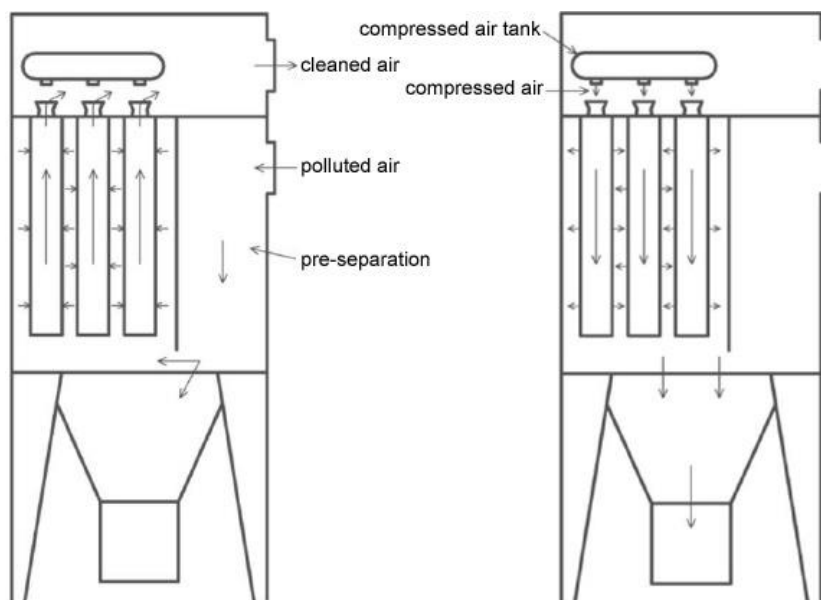

Fig. No.4 Filtration scheme

Fig. No.5 Scheme of filters regeneration

6. ASSEMBLY AND STARTUP

6.1 Description of mounting

Before the assembly of the device in the place of use, check if the device is complete, and if it is not damaged, or there are indentations, etc. The appliance is delivered in two assemblies, so it should be installed by means of adequate lifting devices and by a specialised assembly team.

First, put the supporting structure with the hopper chamber. The supporting frame should be levelled and its legs fastened firmly to the floor. Having installed the first assembly, put the chamber of filters (with the fixed to it regeneration chamber) on it. Handle with care, as the assembly is of large dimensions. At the upper part of the regeneration chamber are installed lifting hooks (for lifting and positioning during the transport and assembly activities).

After the chamber of filters is connected with the supporting structure, seal up the join surface with "silicone" and screw it up thoroughly with bolts. The screws, bolts and "silicone" are delivered by manufacturer along with the device.

The compressed air tank and the electromagnetic valves are delivered to the operator in completely assembled state. Having installed the device, connect it to the external compressed air installation of $0,6 \div 0,8$ MPa. The pressure air must not contain pollutants, oil and humidity.

The connection must be equipped with a cut-off valve, air filter and a dewaterer. These elements are not delivered along with the device.

The nominal diameter of the compressed air connection (for the device of 9 cartridge filters and at the nominal diameter of the compressed air tank of 8") should be 1"1/2.

6.2 Start-up

Upon first operation of the compressed air installation (of the device), check if the connected part of the compressed air system is sufficiently cleaned of the metal particles, rust, etc., because the membrane of the electromagnetic valves would get damaged. If in the first stage of start-up there is not enough air flow intensity (in the system) – this means the valves are not tight enough. Shut the cut-off valve in the supply of the compressed air tank. Wait until the air pressure in the system reaches $0,6 \div 0,8$ MPa, and then quickly open the cut-off valve. The fan chamber with the Ex fan inside – is located on top of the filtering unit – see Fig. No.3.

Connect the electrical system, power supply and the control units – strictly according to the enclosed Connection Diagram Fig. No.7, 8 and 9. As the control system is very complicated, any activity of device connection/energizing must be carried out by an authorised installing team with qualifications. The filtering unit and the fan should be connected to the equilibrating grounding profile.

Connect the motor with reference to the adequate data placed on the nominal data plate and in conformity with the Connection Diagram on the cover of the terminal box (fastened to the motor).

Switchgear A1 should be mounted in area, beyond the explosion hazard zone.

6.3 ATEX Directive

BIG-10000/Ex filtering unit has been classified, according to the 2014/34/Ex Directive and therefore, it is important to take precaution measures during the installing and start-up, and follow subsequent aspects:

- **As the filtering unit is of Category 3D, it should be installed according to the PN-EN 60079-0:2013, PN-EN 1127-1:2011, PN-EN 13463-1:2010 standards, therefore the installer must be thoroughly acquainted with the contents of these standards.**

- Installer should know the ATEX Classification of installing zones, as well as the hazard connected with the atmosphere of explosion risk. Especially, here is important the hazard of explosion, of fire, with the purpose of selection of suitable protection sorts.
- Any activities, related to the installing, necessarily must be performed by a specialised assembly team (after being instructed).
- Having completed the assembly, check the conductivity between the subsequent parts of the device, and check if the maximum resistance does not exceed 10^6 Ohm.
- Grounding of the device and of its parts should be carried out and examined by an authorised person, according to being in force regulations (in this range).
- Any device modification / change, within the construction and mounting, without the consent of deliverer shall cause the invalidation of conformity with requirements of ATEX Directive.

6.4 Precautions measures

- Check if the lifting devices are suitable, approved for use and used by authorized operators;
- During the activity of displacement and assembly – it is important to point out the hazardous zones, that no other people in the vicinity (incidental workers) would enter these zones;
- Transport, assembly and start-up should be executed exclusively by authorized employees, who have been instructed properly and approved by User;
- Prior to any activities connected with mounting and start-up, it is important to get acquainted with the contents of the present Use and Maintenance Manual.

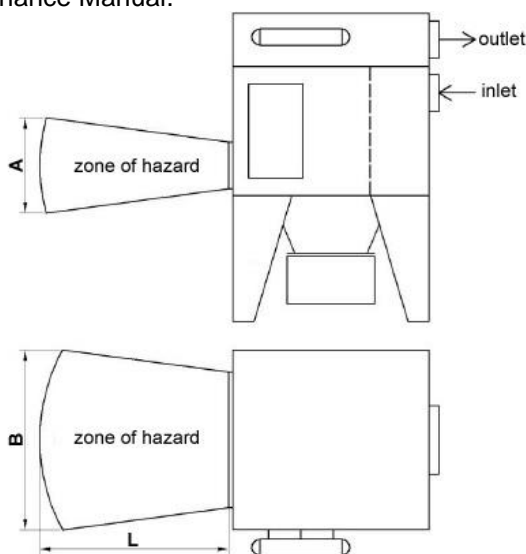

Fig. No.6 – Decompression panel – Zone of hazard

Table No.2 – Dimensions of zones

	A [m]	B [m]	L [m]
BIG-10000/Ex	4	4	14

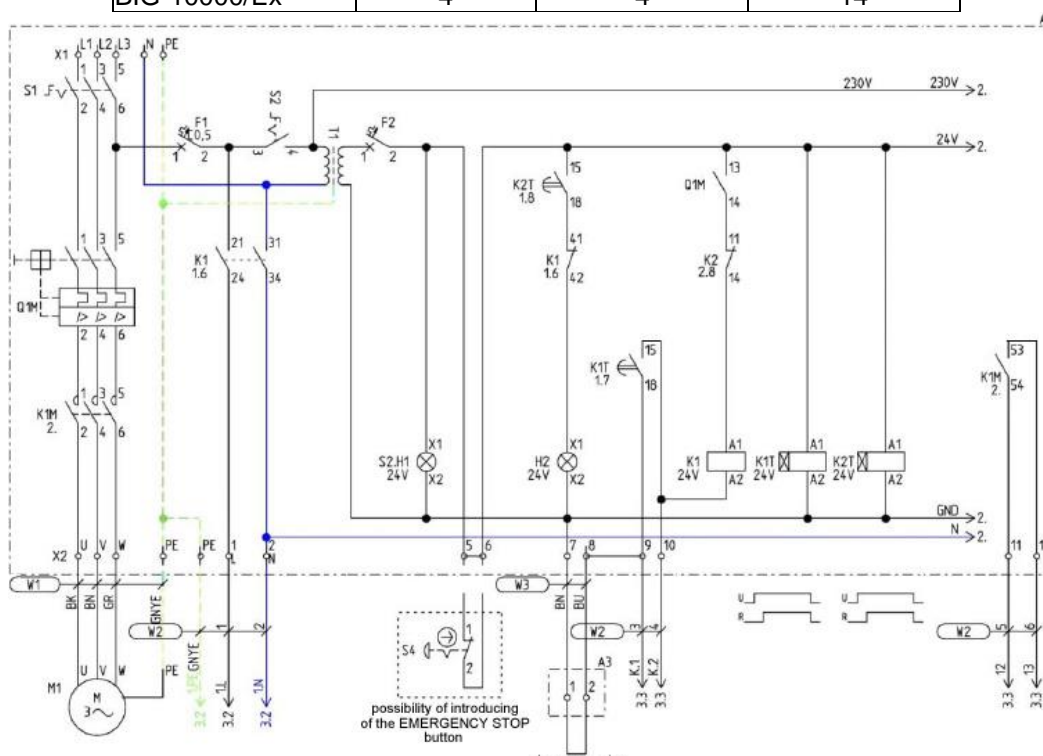

Fig. No.7
decompression membrane

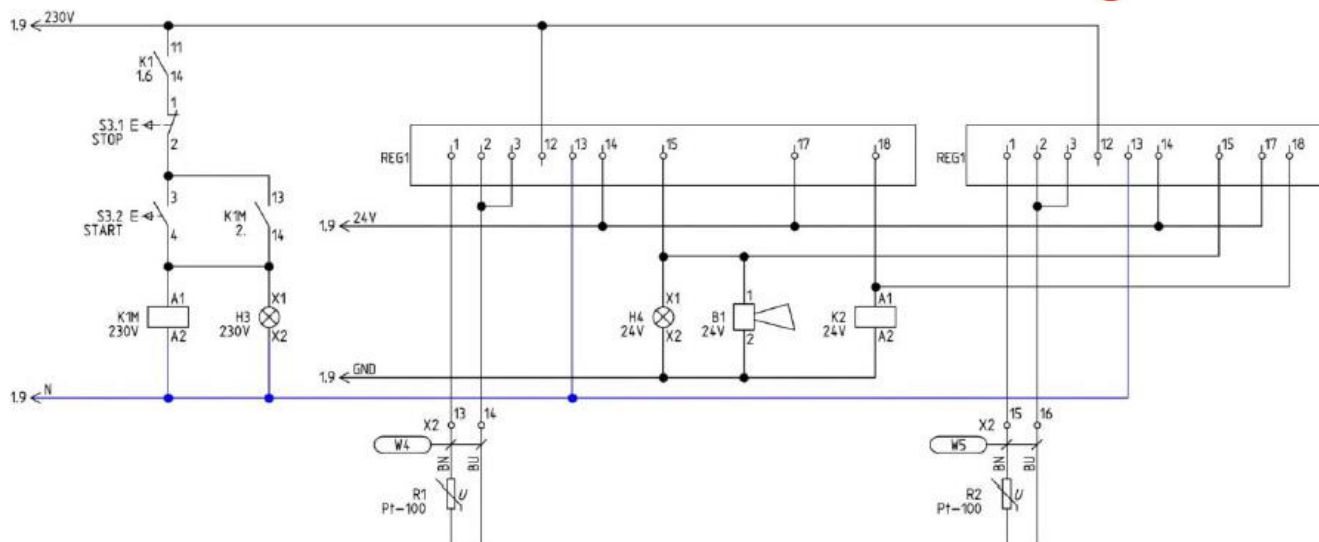

Fig. No.8

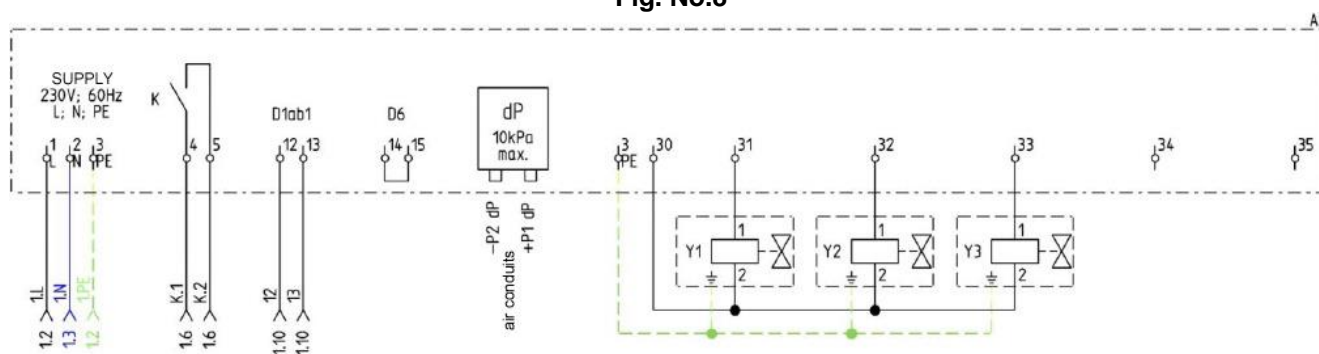

Fig. No.9

7. OPERATIONAL USE

The filtering unit is designed for filtration of the air, at the workplaces, according to the purpose of application as described in Section 2 of the present Use and Maintenance Manual.

7.1 Description of the control system

Control unit is designed to operate the filtering unit, providing automatic regeneration of surfaces of the filters, by means of cyclical impulses of compressed air. The control system consists of subsequent assemblies: switchgear **A1**, micro-controller **A2** and a terminal box **A3**. In the housing of the switchgear **A1** are included electrical elements providing the appropriate and safe work of the whole filtering unit.

Power supply 3x400 ± 10%; 50Hz ± 1%; L1; L2; L3; N; PE.



Fig. No.10 – Switchgear A1 – Cover



Fig. No.11 – Switchgear A1 – internal view

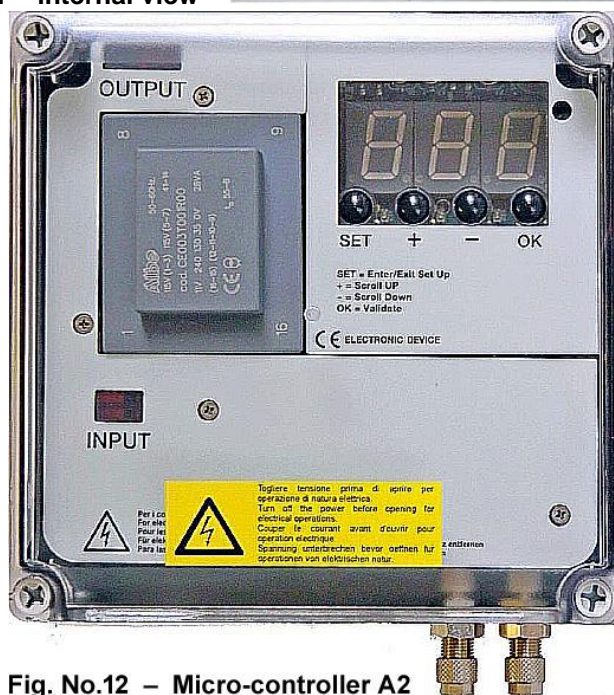

Fig. No.12 – Micro-controller A2

Micro-controller **A2** provides control of the electromagnetic valves – the function is described in Section 7.2. Supply 230V \pm 10%; 50Hz \pm 1%; L; N; PE



Fig. No.13 – Terminal box A3

The **A3** terminal box connects the cable to the sensors on the venting panel, with the output cable, (going out of the Switchgear **A1**). When the cable on the panel is interrupted (during the explosion), the device automation disconnects the fan and the system of regeneration of filters. Any electrical connections ought to be performed in conformity with the above placed Connection Diagram – see Fig. No.7, 8, 9.

Motor in ATEX execution is secured with the motor switch with protection against the blocked startup, overload, short-circuit- and fade of one phase. Additionally, the motor is protected by the **PTC** sensor, installed directly within its windings, as a protection against the excessive overheating.

7.2 Use of the A2 micro-controller Display/Keypad

There are four round buttons on the front panel for controlling the device and turning on the display as shown in the following figure.

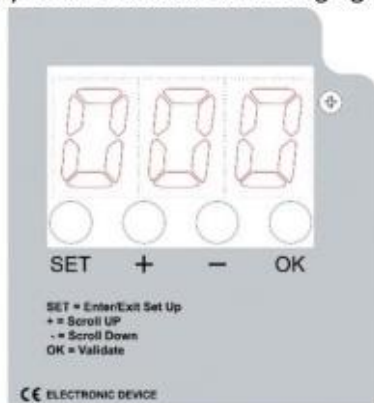

Figure 1

- Press SET to open and close the programming menu and activate the manual solenoid test by selecting function F06.
- Press + and – to select a function, increase/decrease values, view the total hour counter (+) and the maintenance counter (-).
- Press OK to confirm data and reset the alarms.

Menu Diagram

How to access programming:

- Press SET (see figure 2).

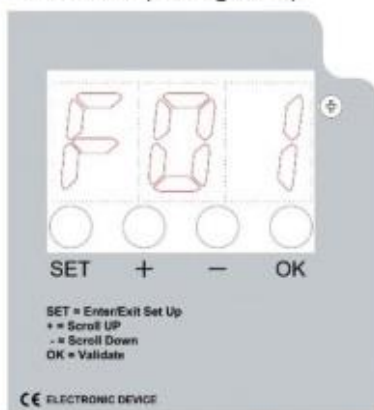

Figure 2

- Press + and – to select the required function.
- Press OK to confirm.
- Increase or decrease the value of the parameter.
- Press OK to confirm and exit.
- Press SET again to exit programming mode.

List of Functions

- **F01:**
Configuring the operation mode.
Possible values: 0 – Manual (Δp excluded)
1 – Automatic (Default) (Δp included)
2 – Automatic with forced cycle (Δp included)
3 – Proportional (Δp included)
- **F02:**
Solenoid activation time.
Possible values: 0.05" – 5.00" step 0.01".
Default = 0.20".
- **F03:**
Washing pause time between solenoid valves.
Possible values: 001" – 999" step 1".
Default = 020".
- **F04:**
Number of connected outputs.
Possible values: 01 – 16 step 1.
Default = 001.
- **F05:**
Output voltage setting.
Possible values: d24, a24, 115, 230.
Default = a24.
- **F06:**
Manual output activation.
Possible values: 1 – number of outputs set in F04.
Press SET to activate the set output.
- **F07:**
Zero dP threshold.
Possible values: 0.00 kPa – 3.99 kPa step 0.01.
Default = 0.00 kPa.
- **F08:**
Cleaning cycle start threshold.
Possible values: 0.00 kPa – 3.99 kPa step 0.01.
Default = 0.80 kPa.
- **F09:**
Cleaning cycle stop threshold.
Possible values: 0.00 kPa – 3.99 kPa step 0.01.
Default = 0.40 kPa.
- **F10:**
Max DP Alarm Threshold (Filter Clogging)
Possible values: 0.00 kPa – 3.99 kPa step 0.01.
Default = 3.00 kPa.
- **F11:**
Fan on recognition mode.
Possible values: 0 from contact – 1 from dP.
Default = 1 from dP.
- **F12:**
dP threshold for fan on recognition if F11=1.
Possible values: 0.00 kPa – 3.99 kPa step 0.01.
Default = 0.10 kPa.
- **F13:**
Number of post cleaning cycles after stopping the fan.
Possible values: 01 – 99 step 1.
Default = 01.
- **F14:**
Post cleaning mode pause time between solenoid valves (fan off).
Possible values: 001" – 999" step 1".
Default = 010".
- **F15:**
Maintenance frequency expressed in tens of hours (e.g.: 1=10h, 10=100h).
Possible values: 001 – 999 step 1.
Default = 100 (=1000h).
- **F16:**
Maintenance deadline alarm enable.
Possible values: 0 (disabled) – 1 (enabled).
Default = 0 (disabled).
- **F17:**
Maintenance hour counter reset.
Possible values: 0 (disabled) – 1 (reset).
Default = 0 (disabled).
Note: The maintenance hour counter will be reset and the F17 parameter will be set back to 0 by setting F17 to 1.
- **F18:**
Precoating function enabling.
Possible values: 0 (disabled) – 1 (enabled).
Default = 0 (disabled).
- **F19:**
dP threshold for precoating function.
Possible values: 0.00 kPa – 3.99 kPa step 0.01.
Default = 2.00 kPa.
- **F20:**
Enabling Minimum DP Alarm function.
Possible values: 0 (disabled) - 1 (enabled).
Default = 0 (disabled).
- **F21:**
Min DP Alarm Threshold (Broken Sleeve/Cartridge)
Possible values: 0.00 kPa – 3.99 kPa step 0.01.
Default = 0.20 kPa.
- **F22:**
Selection of minutes or hours for Forced Cleaning Cycle. (Only if the operating mode F01 = 2)
Default = Minutes (0 =minutes, 1 =hours).
- **F23:**
Setting time interval for Forced Cleaning Cycle in relation to the choice of F22.
Setting values: 1 - 999 step 1.
Default = 240 (240 minutes).

Alarms

The unit runs a number of checks during the start-up cycle and during normal operation. The possible alarms and respective solutions are shown in the following table.

ALARMS TABLE

Alarm number	Description	Action
E01	F05 set to 24Vdc – AC jumper detected	- For 24Vdc, switch the device off and move the AC/DC jumpers to DC. Jumper table p. 12. - For 24Vac, press OK, then press SET, set the function F05 using "+" and "-", select A24 and press OK to confirm.
E02	F05 set to 24Vac – DC jumper detected	- For 24Vac, switch the device off and move the AC/DC jumpers to AC. Jumper table p. 12. - For 24Vdc, press OK, then press SET, set the function F05 using "+" and "-", select d24 and press OK to confirm.
E03	F05 set to 24Vac or dc. Voltage out of range detected	- To use 24V valves, switch the device off and move the output voltage selection jumper to 24V. Jumper table p. 12. - If the jumper is in the correct position, press OK, then SET, select the F05 function with "+" and "-", set 115 or 230 (as jumper) and press OK.
E04	F05 set to 115V. Voltage out of range detected	- To use 115V valves, switch the device off and move the output voltage selection jumper to 115V. Jumper table p. 12. - If the jumper is in the correct position, press OK, then SET, select the F05 function with "+" and "-", set 115 or 230 (as jumper) and press OK.

E05	F05 set to 230V. Voltage out of range detected	- To use 230V valves, switch the device off and move the output voltage selection jumper to 230V. - If the jumper is in the correct position, press OK, then SET, select the F05 function with "+" and "-", set a24, d24 or 115 (as jumper) and press OK.
E06	Solenoid valve current lower than minimum threshold or disconnected solenoid valve	Check correct connection of the solenoid valve and respective data. The alarm is self-reset.
E07	Solenoid valve current higher than maximum threshold	Check correct connection of the solenoid valve and respective data. The alarm is self-reset.
E08	Output short circuit. Alarm cannot be reset	Switch the device on and back on after having checked the solenoid valve system.
E09	dP maximum pressure exceeded (F10)	Check state of filtering elements.
E10	dP sensor hardware offset out of range.	The self-calibration of the dP sensor has determined that a value is out of range. Disconnect the air tubes and repeat the function. Take the device to be serviced if the alarm occurs again.
E11	Maintenance deadline reached	Carry out maintenance.
E12	dP sensor full-scale value reached	Check state of filtering elements. IMPORTANT: Running in this condition may damage the device.
E13	Minimum DP alarm value ranging from F12 to F21 (warning: the alarm is generated with a fixed delay of 60 seconds).	Check the status of the filtering elements.

Description of Operation

The installed SW version and the symbol ---, meaning that coherence between settings stored in E2Prom and the set jumpers is being checked, will appear on the display when the economiser is powered up. A corresponding error code will appear in case of discrepancies between settings (see Alarms Table). Only editing functions will be allowed on the unit. The operator may switch off the unit and configure the jumpers correctly.

Symbol **0_0** will appear on the display if the test is entirely successful. The following pages will then appear:

- In automatic mode (F01=1):
 - dP value alternating with OFF if the enabling contact (14-15) is open
 - dP value alternating with -0- if the enabling contact (14-15) is closed and the fan is off
 - dP value only if the fan is enabled and active.
- In manual mode (F01=0):
 - OFF if the enabling contact is open (14-15)
 - -0- if the enabling contact (14-15) is closed and the fan is off

Manual operating mode F01=0

The economiser will work as a programmable cycle sequencer in manual mode. The connected outputs will be activated at the programmable frequencies. Manual mode can be activated by accessing the configuration menu and setting F01 to 0. F02 and F03 will set the activation time and the pause time, respectively.

Automatic operating mode F01=1

By selecting automatic mode (F01=1), the economiser will work autonomously and can carry out the pneumatic washing cycle only when needed. The device will start the washing cycle if the obstruction is higher than Threshold_DP_Start (F08). Washing is suspended when obstruction drops under Threshold_DP_Stop (F09) level until it reaches a value higher than the Threshold_DP_Start threshold once again. When washing is active, the economiser respects the times set in F02 (operating time) and F03 (pause time).

Automatic mode with forced cycle F01 = 2

Identical to the automatic mode, except for the fact that it is possible to obtain a cleaning cycle with the activation of the solenoid valves connected without reaching the Threshold_DP_Start (F08). The forced cleaning interval may range from 1 to 999 h and can be selected through function F22 and F23.

Proportional mode F01 = 3

With the proportional mode, the economiser will work in full autonomy, initially setting the DP_Start threshold (F08), activation time (F02) and pause time (F03). When the Start Cleaning threshold is exceeded, the solenoid valves are automatically activated in sequence. If the dP threshold drops below 15% at the end of an entire cycle of pulses of the connected solenoid valves, the washing is suspended until pressure returns to a value above the Start Cleaning dP value. If the dP value does not drop below 15% of the Start Cleaning threshold, the frequency of the cycle time is automatically reduced in proportion with each entire cycle of pulses of the connected solenoid valves, until a minimum cycle time between solenoid valves reaches 10 seconds. The minimum threshold of 10 seconds has been chosen so as not to hamper the dispensing of air by the compressor connected to the filter.

Cleaning function with fan off (PCC)

This function allows to carry out one or more cleaning cycles (the number of cycles is defined by F13) when the fan is off. The on or off state of the fan may be determined by the state of the contacts 12-13 (contacts open = fan off) if F11=0, or may be determined automatically (with F11=1) when the dP pressure drops under the threshold defined in F12. The pulse time of the valves will always be that defined in F02, while the pause time in this case is defined in F14.

The display alternately shows the number of the valve activated and the word CCP.

Number of output selection

The number of outputs (solenoid valves) on which the economiser will run the cleaning cycle can be selected. Cleaning will be carried out in order from the first to the last solenoid valve. The valves can be adjusted by the F04 function.

Precoating function (F18=1)

This function is used to carry out precoating. Precoating is a filtering element treatment carried out with precoating powder. Washing and manual output activation is suspended during precoating until the precoating thresholds defined in F19 is reached.

The Δp value and the message PC (precoating) will appear alternatively on the display.

dP zero calibration (F07)

This function is used to reset dP reading with the fan off.

Increase or decrease the value shown by pressing "+" and "-" as required. This value will be subtracted from the value read by the dP sensor.

dP sensor self-calibration

This function allows to reset dP reading with the fan off automatically.

Hold "SET" and "OK" pressed at the same time with the device off. The message "CAL" will appear after the start-up test. Release the buttons. The unit will go back to normal state after a few instants. Automatic calibration is complete.

Fuse

A fuse which can be reset in case of need is located near the power terminal board. Use a delayed fuse 5x20mm as shown in the table on page 12.

7.3 Startup of the system

Connect the elements strictly according to the diagram, using cables selected with reference to current-carrying capacity of the receivers.

- Switch on the protections in the switchgear **A1**.
- Check if the **F1** fuse in the micro-controller **A2** is not damaged.
- Apply the supply voltage with the **S1** disconnecter in the switchgear **A1**.
- Switch on the system with the **S2** switch.
- The fan can be safely started with the green button **S3.2** – under the condition that the red lamp **ALARM** (on the **A1** switchgear door) is not on.
- When the green lamp (built in the double button **S3**) is lighting – this is the information that the fan is in operation and the filter regeneration system is switched on; {To make sure, the filter regeneration system is functioning – after the first device startup, examine the device, check (after the ALARM state emerges) the communicates emerging on the micro-controller display}. Additionally, after the first start-up, check the rotation sense of the fan impeller.
- To switch off the fan – press the red button **S3.1**.
- The green lamp (built in the button) goes off – subsequently, proceeds the final filters regeneration – at any time the fan can be started again.

7.4 Alarms

In the device can appear states of alarms, caused by:

- activation of the motor protective switch
- interruption of the sensors on the decompression membrane,
- alarm from the micro-controller (controlling the function of the electromagnetic valves) – description in 7.2.

These alarms are signalled by the red lamp **H2** (placed on the door of the switchgear **A1**). When the alarm occurs, it is important to disconnect the power supply by means of the **S1** disconnecter. Next, find the failure/damage, find out its/their reason and remove the malfunction. After the failure is removed correctly, and the power supply is applied again – the filtering unit can be operated again.

On the appliance is installed a temperature sensor. At the moment when the temperature of the conveyed air exceeds 40°C – an acoustic signal (buzzer) activates – this is signalled by the H4 “HIGH TEMPERATURE” lamp. Operators should react and switch off the device. If the device is not switched off by the operator – it will work longer and when the temperature exceeds 45°C – it will switch off automatically. Indications of temperature are shown in the upper line of the governor / thermostat REG1.

CAUTION: If the fan works incorrectly, please contact the Deliverer.

7.5 Removal of dust

The dust must be emptied systematically, when the waste container is filled up. User has to give instructions to the operating personnel, that **while disconnection of the waste container from the hopper (by means of the blocking lever) they must take precautions**. In case when the waste container is not sufficiently supported from underneath, it can be rapidly discarded (thrown away). Mind, the workers should necessarily wear antistatic clothes. Additionally, the waste container (while withdrawal, mounting) must be placed on an antistatic pad. This activity should be carried out, after the fan is switched off and the device disconnected from the power supply mains. When the waste container is fastened back to the device, mind that the contact surfaces are clean and the seal is suitable to the edge between the waste container and the hopper chamber.

7.6 Measures of precautions during the maintenance

- The filtering unit must be used according to the present Use and Maintenance Manual and according to the being in force regulations.
- Maintenance steps / activities should be executed by authorised workers after the instructions.
- In the course of operational use, be careful that no ignition sources (e.g. sparks, cigarette butts, embers) gets into the device.
- During the emptying of the waste container and during any other activity near the filtering unit, it is important to wear antistatic clothes. Put the antistatic pad/rug underneath the waste container.
- Directly, at the filtering unit, and in the vicinity – do not use mobile phones and other devices emitting electromagnetic waves.

8. TROUBLESHOOTING GUIDE

Table No.3

	Problem	Possible reason	Corrective action
1.	Decrease in the inlet air volume after the period of correct function	Regeneration runs incorrectly, due to too low pressure of the compressed air.	Adjust to obtain the pressure of 0,6÷0,8 MPa in the system
		The cleaning time and work time are not adjusted correctly	Adjust the work of micro-controller according to the present Use and Maintenance Manual
		Too high humidity of the filters, caused by the humid air in the compressed air system	It is important to dewater the compressed air tank, check the state of the compressed air system
		Dust emerges in another area, due to temperature higher than 40°C of the inlet air	Limit the temperature at the inlet
2.	Dust emerges outside the device	The cartridge filter is not tightly connected or damaged	Replace the cartridge filter or improve its mounting
		The dust is of another sort than stated in the instruction.	Contact the manufacturer
		Filtration efficiency is too low	Contact the manufacturer
3.	Dust is appearing outside the filtering unit after a longer period of correct work	The cartridge filter is damaged	Replace the faulty element
		The mounting flange (of the cartridge filter) is deformed or damaged	Replace the faulty element

9. MAINTENANCE AND REPAIR

9.1 Cartridge filters

It is necessary to undertake a visual control of the cartridge filters, at any case when the waste container (underneath the hopper chamber) is emptied of the dust. Examine the state of the mounting elements, the state of the filtration surface, the degree of pollution, the presence of damages, etc. – through the inspection door. Additionally, this revision should be carried out in case when any improper function of the device is noticed.

In case the cartridge filters are damaged or worn out – replace them for new. The filters should be drawn out, beginning from the filter closest to the inspection door. Before User draws out the filter, first release the mounting nuts, turn the filter itself and take it out.

9.2 Fan

Technical revision and maintenance of the fan should be executed according to the instruction of the fan. In case when faulty function of the fan is noticed, please contact the producer. The fan motor must be submitted to systematic maintenance, to provide correct function and safety. Follow steps strictly as described in the instructions of the fan manufacturer. When necessary, replace the fan or motor for new and this can be carried out exclusively by an authorised personnel.

9.3 Compressed air tank.

The compressed air tank must be submitted to technical revision and maintenance, according to the valid regulation on the pressure devices. Periodically, examine all the connections on the compressed air tank. It is important to dewater the tank, through the connection (installed in the lower part of the tank).

9.4 Electromagnetic valves

Electromagnetic valves do not require current maintenance. Simply, it is sufficient to check the electrical connections, the state of grounding and tightness on the pneumatic installation.

It is recommended to replace the valves after 2 years of use, and not later than after 4 years of operational use (but in this case, contact the producer of the filtering unit).

9.5 Recommended periods of technical revisions and maintenance of the filtering unit.

Table No.4

Current check and action after the fill up state of the waste container	Removal of dust from the waste container
Current revision	Systematic cleaning of the device and its assemblies, in order to avoid accumulating of the dust layer exceeding 5 mm
Every time, the waste container is emptied	Control visually the cartridge filters, through the revision door.
Once a month	Check the state of the device grounding, and examine the conductivity between the all assemblies of the device, if the maximum resistance does not exceed 10 ⁶ Ohm

Once for 2 ÷ 3 months	Overall visual control of the supporting construction (base frame) and of the housing. Examine the screw connections and anti-corrosion protection.
Once for 12 months	Check the state of the electrical connections and of the external installation of the compressed air, check the connections of the electromagnetic valves.
Once for 12 ÷ 18 months	Visual control of the compressed air tank and of its dewaterer. When, (with reference to the environment and the state of the pressure air), it is necessary – this revision should be executed more frequently.
Fan – Use and Maintenance Manual of the fan	Follow as according to the instruction
Motor – Use and Maintenance Manual of the of the motor	Follow as according to the instruction

9.6 Measures of precaution during the revision activities and the maintenance

- Maintenance and revision ought to be executed with reference to the being valid regulations, and with the present Use and Maintenance Manual and carried out by authorised workers after being instructed.
- Any activities on the device must be carried out after the fan is switched off and disconnected from the power supply system.
- During these activities it is important to wear antistatic clothes.
- While emptying the waste container of the dust, during the dismantling of the container and its mounting – the waste container must be placed on the antistatic pad/rug.
- Near the device, do not use mobile phone, and other devices emitting electromagnetic waves.
- The filtering unit cannot be submit to modification or complemented with functional parts or control elements, without the consent of the Deliverer.

10. OCCUPATIONAL HEALTH AND SAFETY

- Assembly, installing, start-up and maintenance can be carried out after getting acquainted with the contents of the present Use and Maintenance Manual.
- For safety reasons, the device must be connected to the power supply system – strictly according to the enclosed Connection Diagram, and with the being in force regulations within the range of personal protection against electric shock.
- Connection to the power supply system should be executed by an authorised person with electrical qualifications.
- Maximum operational pressure of the compressed air, for safety reasons, must not exceed 0,8 MPa.
- Any activities, connected with repair and technical revisions as well as emptying the filled up waste containers (underneath the hopper chamber) – should be executed after the fan is switched off and the device disconnected from the power supply.
- The fan as a rotating appliance – constitute a potential source of hazard, therefore installing, start up and maintenance should be carried out by qualified personnel.
- As the filtering unit is equipped with a decompression panel VMP 450x800 (0,34m²) – the whole device should be placed in such a way, that there is provided free access to the control system, and additionally, (in case of explosion) there should be safety area for the discarded vent panel. During the explosion, the control connection shall be interrupted and the filtering unit stops functioning.

11. TRANSPORT AND STORAGE

BIG-10000/Ex filtering unit is transported in two assemblies, wrapped in foil, placed on transport pallets. During the time of transport, the assemblies must be located vertically and protected from overturn (being knocked down) and from displacement. The fan chamber is a separate assembly, it should be placed on a transport pallet too. Handle with care during the lifting the subsequent assemblies, during the transport, unloading and mounting. The device has to be stored in close rooms and in dry rooms and in areas of efficient ventilation.

12. TERMS OF WARRANTY

The period of warranty for the purchased device is indicated in the **Card of Warranty**. The warranty does not comprise:

- mechanical damage and malfunctions caused by User,
- device failures caused during the use which is in contradiction with the purpose of application and with the present Use and Maintenance Manual,
- malfunctions resulting from the improper transport, storage or incorrect maintenance.

Infringement of the Section 3 “Reservations of Producer” of the present Use and Maintenance Manual and, especially modifications undertaken by User on one’s own or use in contradiction with the purpose of application – shall result in the loss of warranty validity.

13. DECLARATION OF CONFORMITY



DECLARATION OF CONFORMITY EC No. _____

Manufacturer (eventually also the authorised representative / importer):

name: **KLIMAWENT S.A.**

address: **81-571 GDYNIA, ul. Chwaszczyńska 194**

A person, authorised for issuing the technical documentation:

name and address: **Teodor Świrbutowicz, KLIMAWENT S.A.**

hereby declares that the product: **Filtering unit**

type / model: **BIG-10000/Ex**

serial number: _____

year of production: _____

Meets the requirements of the subsequent European Directives:

2006/42/EC Directive of the European Parliament and of the Council of the 17 May, 2006 on machinery, amending the 95/16/EC Directive (recast) / Official Journal EC L157 of the 09.06.2006, page 24);

2014/35/EC Directive of the European Parliament and of the Council of the 26 February, 2014 on the harmonisation of the laws of the Member States, relating to the making available on the market of electrical equipment designed for use within certain voltage limits / Official Journal EC L96 of the 29.03.2014;

2014/34/EC Directive of the European Parliament and of the Council of the 26 February, 2014 on the harmonisation of the laws of the Member States, relating to the equipment and protective systems intended for use in potentially explosive atmospheres / Official Journal EC L96 of the 29.03.2014 /

1999/92/EC Directive of the Council of the 19 December, 1999 on minimum requirements regarding safety of health protection of workers employed at workplaces where explosive atmosphere is likely to occur / Official Journal No.138, Pos. 931/

is in accordance with the requirements of the following harmonised standards:

EN ISO-12100:2012 Safety of machinery – General principles of design – Assessment and reduction of hazard

EN 60204-1:2010 Safety of machinery – Electrical equipment of machines – Part 1: General requirements

EN ISO 13857:2010 Safety of machinery – Safe distances to prevent hazard zones from being reached by upper and lower limbs

EN 60079-0:2013-03/A11:2014-03 Electrical appliances in areas of gas explosion hazard – Part 0: General requirements

EN 1127-1:2011 Explosive atmospheres – Explosion prevention and protection. Basic terminology and methodology

EN ISO 80079-36:2016-07 Explosive atmospheres – Part 36: Non-electrical appliances in areas of explosion risk Methodology and requirements

place, date

*signature of the
authorised person*

*name, surname,
function of the signatory*

NOTES:

NOTES:

NOTES: