

Use and Maintenance Manual



Radial fan / blower DOG-1

843W27-DOG-1-31.05.2019/EN

Contents:

1.	Introductory Remarks	2
2.	Application.....	2
3.	Reservations of Producer.....	2
4.	Technical Data	3
5.	Structure and Function	3
6.	Assembly and Start-up.....	5
7.	Operational Use	5
8.	Troubleshooting Guide	5
9.	Maintenance	5
10.	Occupational Health and Safety.....	6
11.	Transport and Storage	6
12.	Terms of warranty	6
13.	Sample of the Declaration of Conformity	7

1. Introductory Remarks

The purpose of the present Use and Maintenance Manual is to supply User with directions within the range of application, installation, start-up and the operational use of the **DOG-1 blower**.

Installing, start up and operational use are exclusively admissible after getting acquainted with the contents of the Use and Maintenance Manual.

With regard to continuity of work carried on improvement of our products, we reserve for ourselves the revision possibility of the draft and technological changes improving their functional features and safety.

The construction of the **DOG-1 blower** meets the requirements of the current state of technology as well as the safety and health assurances included in:

- **2006/42/EC Machinery Directive** of the European Parliament and of the Council of May 17th, 2006 on machinery – amending the 95/16/EC (recast) */Journal of Laws EC L157 of 09.06.2006, page 24/*
- **2014/35/EC Directive** of the European Parliament and of the Council of February 26th, 2014 on the harmonisation of the laws of the Member States relating to the making available on the market of electrical equipment designed for use within certain voltage limits. */Journal of Laws EC L96 of 29.03.2014/*

The device has been constructed and produced on the basis of following harmonized standards:

- **EN ISO-12100:2012** – “Safety of machinery. Basic concepts, general principles for design. Risk assessment and risk reduction”.
- **EN 60204-1:2018-12** – “Safety of machinery. – Electrical equipment of machines. Part 1: General requirements”.

2. Application

DOG-1 blower is constructed for local drying the walls in humid rooms. Additionally, it is efficient in applications for rescue services and for fire departments units.

Special applications:

- Supply of fresh air (during the rescue actions) to the areas without ventilation. Fresh air can be delivered from the areas beyond the polluted zone and conveyed within distance of several dozens of metres. The necessary fresh air supply is sufficient for 10 people.
- Drying of the internal surfaces of fire hoses. The air is pumped into the fire hose under high pressure, by means of the turbine (inside the blower).

As the device is lightweight and is equipped with a quick-connector (for hose attachment), it is very convenient in use.

3. Reservations of Producer

1. Manufacturer is not liable for any consequences following from the operational use that is in contradiction to the purpose of application.
2. Do not install any additional elements not belonging to the normal device structure or accessory set.
3. Any structural changes or modifications on the appliance on one's own are not permitted.
4. Maintenance and any repair ought to be carried out by an authorised person.

4. Technical Data

Table No.1

Type	Supply voltage [V]	Motor rate [kW]	Volume flow [m ³ /h]	Maximum vacuum [Pa]	Acoustic pressure level measured from distance		Weight [kg]	Longevity of the turbine (hours of work) [hours]
					1m	5m		
					[dB(A)]			
DOG-1	230	1,6	225	30000	81	78	7	1000

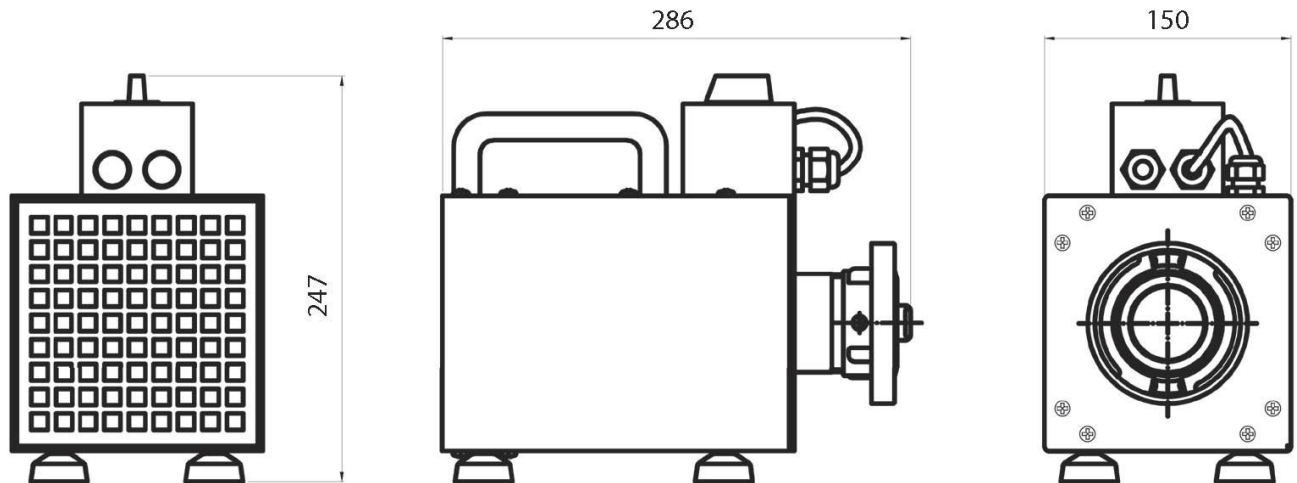

Fig. No.1 – DOG-1, dimensions

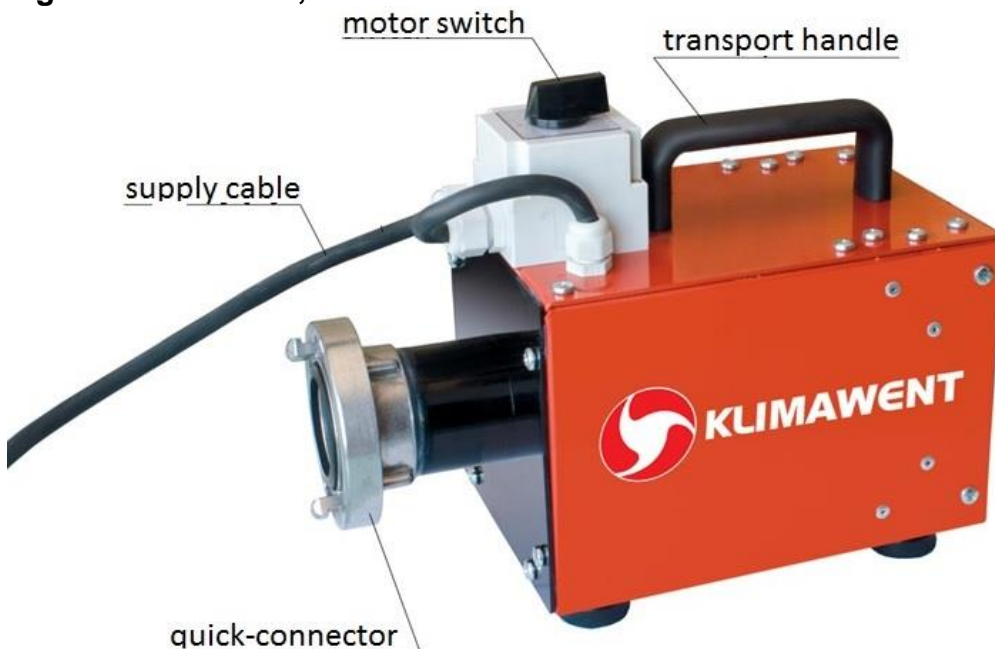

Photo No.1 – DOG-1, structure

5. Structure and Function

DOG-1 consists of a housing, high-pressure turbine and a motor switch. The housing is equipped with a handle to displace the device. On the upper housing part is introduced a switch to operate the turbine. The turbine forces the air into the connected hose.

The appliance is equipped with a standard quick-connector, as a convenient solution for connection of the fire hoses. The pressurised air stretches the hoses, and increased temperature of the forwarded air dries them efficiently (see Photo No.2). The air exiting the blower is heated up by approx. 30°C.



Photo No.2 – Drying up the fire hoses

To dry up the wall, put the blower outlet in the distance of ca. 0,5 metre from the humid wall surface. After the humid wall area is dried up, put the blower in another place (see Photo No.3). It is recommended that there is free access to fresh air for the dried room, in order to create a natural draught in the room.

In spite of not significant volume flow, the blower is efficient in drying because the heated up air is expelled under high pressure, flowing further and enhancing the diffusion of the vapour.



Photo No.3 – Drying up the walls

Supplying of fresh air of increased temperature, (especially in winter), is very important during the rescue actions, in areas of disaster collapse and in other hardly accessible places.



Photo No.4 – Application during the rescue action

The blower is equipped with a 5 metre long supply cable with a plug.

6. Assembly and Start-up

Put the blower on a dry floor surface. **DOG-1 ought to be supplied from a circuit with differential- and over-current protection.** The appliance has to be switched on by means of a motor protective switch on the housing cover. If it is applied for fire hoses, they should be connected to the quick-connector.

7. Operational Use

In the course of use it is important that the fire hose would not get sharp bendings / folds, as these would throttle the air that is forwarded into the hose.

8. Troubleshooting Guide

Table No.2

	Problem	Possible reason	Corrective action
1.	the air is not expelled from the blower	the power supply plug is not inserted in the socket	connect the plug
		the power supply cable is faulty the motor switch is damaged	replace the supply cable replace the motor switch
2.	too low pressure of the expelled air	the fire hose has sharp bends / folds or it is tangled	stretch the fire hose

9. Maintenance

The blower do not require any maintenance activities, it is sufficient to keep the device clean as everyday routine.

10. Occupational Health and Safety

Operational use of the blower is exclusively possible after getting acquainted with the present Use and Maintenance Manual. **DOG-1 blower ought to be supplied from a circuit with differential- and over-current protection.** Manufacturer is not responsible for incorrect function / failure, as a consequence of the device application that is in contradiction with its purpose and designation.

11. Transport and Storage

The blower should be stored in dry rooms and in areas of efficient ventilation, in zones free from aggressive substances.

12. Terms of warranty

The period of warranty for the purchased device is indicated in the “Card of Warranty”. The warranty does not comprise:

- mechanical damage and dysfunctions caused by User,
- device failures caused during use which was in contradiction with the purpose of operational use and the present Use and Maintenance Manual,
- damages being entailed during the improper transport, storage or incorrect maintenance.
- the suction unit – due to its longevity, as specified by manufacturer of the suction unit.

Infringement of the Section 3 “Reservations of Producer” of the Use and Maintenance Manual shall cause the loss of warranty validity.

interference filter	SUPPLY 230V; 50Hz short-circuit protection protection dl=30mA	MANUAL ON / OFF
---------------------	---	-----------------

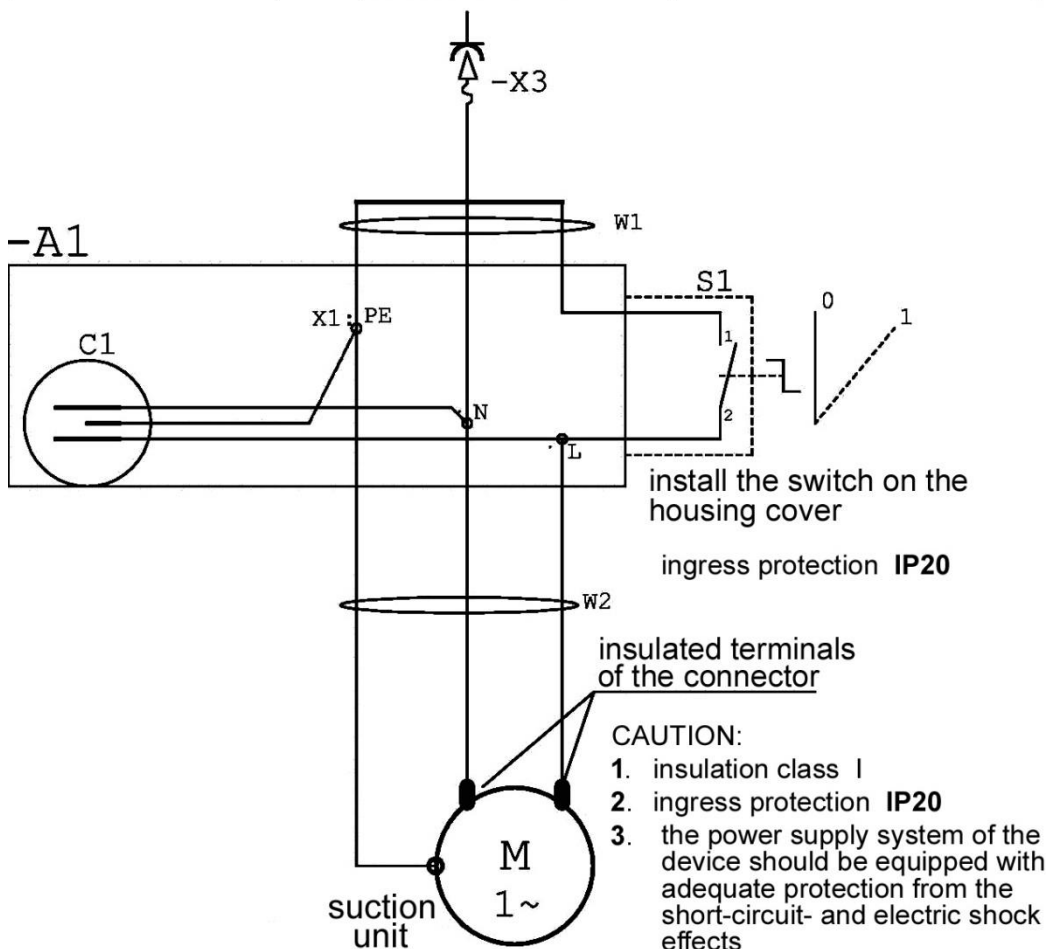

Fig. No.2 – DOG-1, Connection Diagram

13. Sample of the Declaration of Conformity

Declaration of conformity EC No.

Manufacturer (eventually the authorized representative / importer):

name: **KLIMAWENT S.A.**

address: **81-571 Gdynia, Chwaszczyńska 194**

A person, authorized for issuing the technical documentation: Teodor Świrbutowicz, KLIMAWENT S.A.

hereby declares that the appliance:

name: **radial fan / blower**

type/model: **DOG-1**

serial number: year of production:

meets the requirements of the subsequent European Directives:

- **2006/42/EC Machinery Directive** of the European Parliament and of the Council of 17 May, 2006 on machinery – amending the 95/16/EC (recast) */Journal of Laws EC L157 of 09.06.2006, page 24/*
- **2014/35/EC Directive** of the European Parliament and of the Council of 26 February, 2014 on the harmonisation of the laws of the Member States relating to the making available on the market of electrical equipment designed for use within certain voltage limits. */Journal of Laws EC L96 of 29.03.2014/*

The device has been constructed and produced on the basis of following harmonized standards:

- **EN ISO-12100:2012** – “Safety of machinery. Basic concepts, general principles for design. Risk assessment and risk reduction”
- **EN 60204-1:2018-12** – “Safety of machinery. – Electrical equipment of machines. Part 1: General requirements”

.....
place, date

.....
signature of authorised person

.....
name, surname, function
of the signatory

KLIMAWENT S.A.

Supported Employment Enterprise

81-571 Gdynia, ul. Chwaszczyńska 194

phone: +49 58 829 64 80

email: klimawent@klimawent.com.pl

www.klimawent.com.pl

District Court Gdańsk-Północ

in Gdańsk, VII Wydział Gospodarczy

of the National Register of Court

KRS 0000308902 company stock

13.779.200 zł paid in total

NIP: 958 159 21 35

REGON: 220631262

Bank Account: **Santander Bank Polska S.A.**

56 1500 1025 1210 2007 8845 0000

NOTES: