

TELERGO – telescopic extraction arms



TELERGO-FLEX-L-1600



TELERGO-L-3-2000



TELERGO-L-2-2400

Purpose

TELERGO extraction arms have been constructed for effective extraction the welding dust and gas contamination, as well as other small dust particles – directly at the emission source. Important is not to allow the contamination to expand in the process room, preventing it from being inhaled by people. The extraction arms can be applied in any areas where the workspace is limited. Commonly, this is the case in welding schools, where the welding booths are very small. The arm can work as a single appliance, with its own extraction fan, or in a group of local exhausts connected to the main collecting ductwork (with a central fan).

Structure

The extraction arm consists of following elements:

- swivel,
- suction hood with a shut-off damper,
- pipe segments of telescopic construction – the segments are sliding one into the another (in case of TELERGO FLEX the supporting structure is made of the sliders inside the flexible hose).

Pipe segments are made of stainless steel sheet, whereas the swivel of aluminium cast elements. The nominal diameter of the arms is 160 mm. The extraction arm is equipped with a frictional joint located near the swivel.

Operational use

To install the extraction arm on a wall (or supporting column) use a wall bracket. Additionally, the wall bracket is an appropriate installing point for the extraction fan or the connection fitting piece. The pipe-segments can be slid telescopically, one segment can turn within the other segment, providing the most useful position of the suction hood. Adequately adjusted frictional joint gives easy manoeuvrability with the arm. The suction hood is equipped with a shut-off damper to adjust the air volume flow. The TELERGO-L-3-3000 is additionally equipped with a support of the gas spring, improving the manoeuvrability performance.

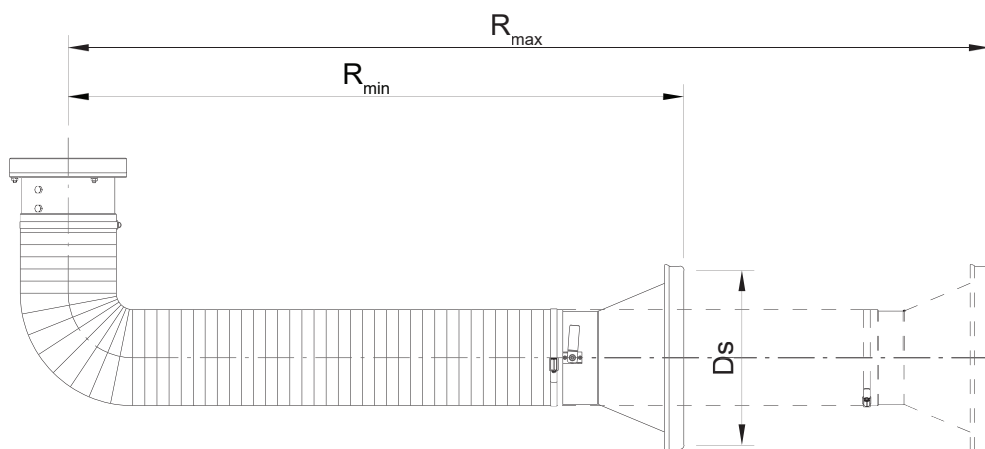

TELERGO-FLEX-L-1600

Technical data

Type	Part no.	Nominal diameter Dn [mm]	Ds [mm]	Recommended volume flow [m ³ /h]	Workrange [m]		Weight [kg]
					R _{min}	R _{max}	
TELERGO-FLEX-L-1600	810R69	160	315	1000	1,1	1,7	10

TELERGO

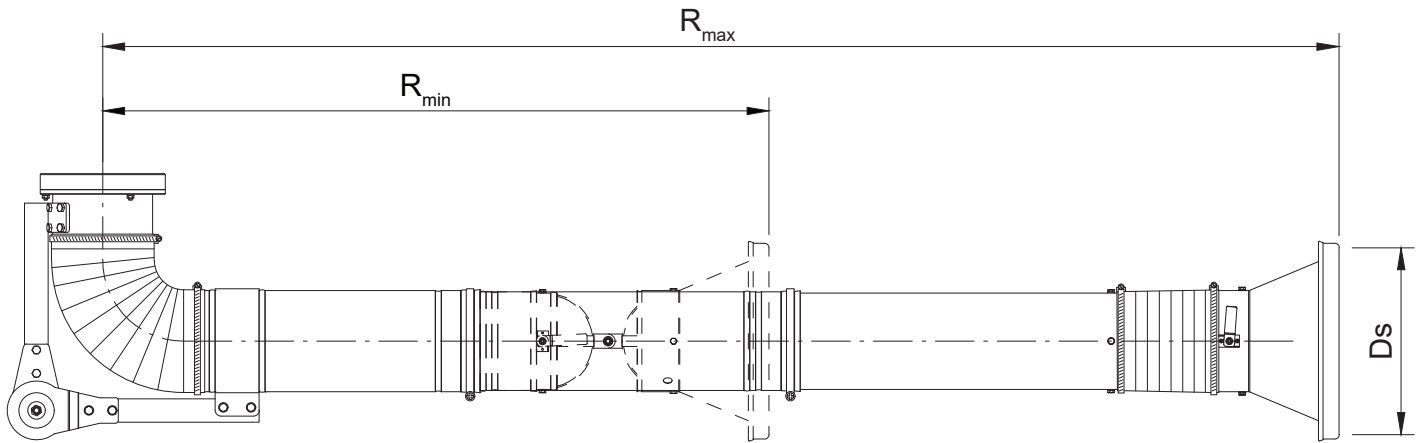

TELERGO-L-3-2000

Technical data

Type	Part no.	Nominal diameter Dn [mm]	Ds [mm]	Recommended volume flow [m ³ /h]	Quantity of pipe segments	Workrange [m]		Weight [kg]
						R _{min}	R _{max}	
TELERGO-L-3-2000	810R67	160	315	1000	3	1,1	2,1	13

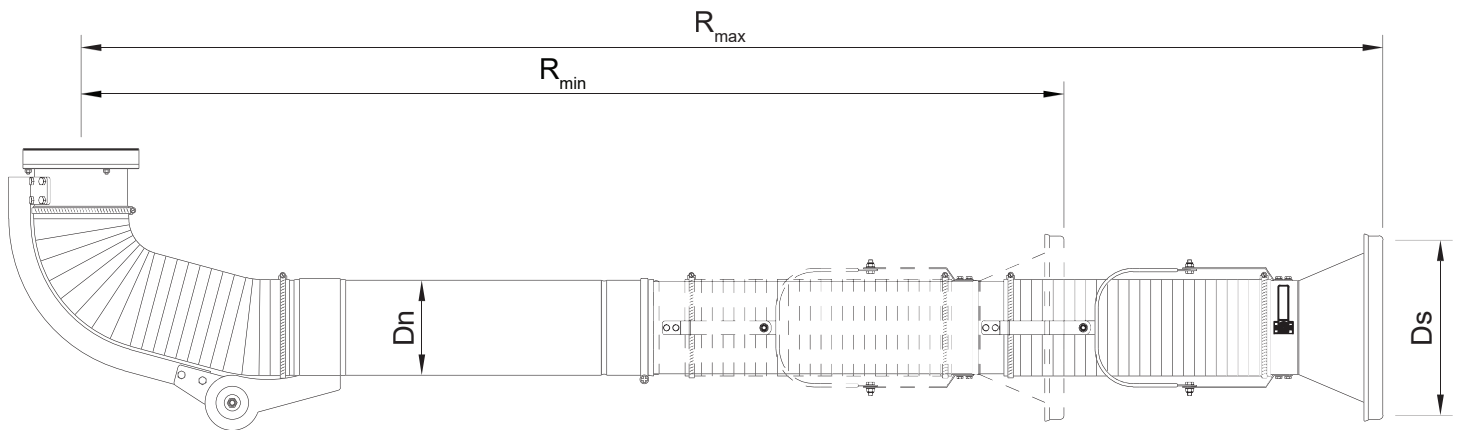

TELERGO-L-2-2400

Technical data

Type	Part no.	Nominal diameter Dn [mm]	Ds [mm]	Recommended volume flow [m ³ /h]	Quantity of pipe segments	Workrange [m]		Weight [kg]
						R _{min}	R _{max}	
TELERGO-L-2-2000	810R63	160	315	1000	2	1,6	2,0	11,5
TELERGO-L-2-2400	810R64	160	315	1000	2	1,8	2,4	13
TELERGO-L-3-3000	810R65	160	315	1000	3	1,85	3,0	15

Hood

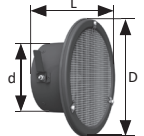
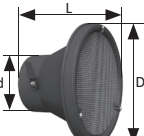
Sort of the hood	Material	Type	Part no.	d [mm]	D [mm]	L [mm]	Weight [kg]	Remarks
	aluminium sheet	LSO-S	810H45	173	340	227	0,72	<ul style="list-style-type: none"> - replaceable inlet wire-mesh - shut-off damper - for extraction arms: TELERGO-FLEX-L-1600, TELERGO-L-3-2000
	aluminium sheet	LSO/Flex	810H42	173	340	227	0,72	<ul style="list-style-type: none"> - replaceable inlet wire-mesh - shut-off damper - for extraction arms: TELERGO-L-2-2000, TELERGO-L-2-2400, TELERGO-L-3-3000

Replaceable inlet wire-mesh ERGO

	Type	Part no.	D [mm]	Weight [kg]	Remarks
	WOLS	834Z31	226	0,06	for the hood LSO-S
WOL	834Z33	287	0,09	for the hood LSO/Flex	

Wall bracket

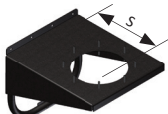
Sort of bracket	Material	Type	Part no.	S [mm]	Weight [kg]
	steel sheet	WB-ERGO-L/S	817W27	277	7

Flow chart

