

RO – rotational arm

Purpose

Rotational arms are enhancing the work range of the hanging ERGO LUX extraction arms. In the basic version, at the end of the rotational arm is fastened an ERGO LUX extraction arm. Whereas, in the “broken” version – ERGO LUX arm has to be fastened at the end of the set consisting of two rotational arms.

Structure

The rotational arm consists of a bearing swivel and the steel duct of rectangular section. Rotational arms RO-L/X of range 1,5 and 2,5 m are equipped with swivels made of aluminium cast rings with a roller bearing, whereas the other rotational arms are featured by steel swivels with slide bearings. Their torsion resistances are minimum, providing easy manoeuvring with the arm within the work area.

A set of arms in basic version – rotational arm RO-2,5-E-L/X and an extraction arm



A set of arms in a “broken” version – rotational arm RO-4-E-L/Y, an rotational arm RO-2,5-E-L/X and extraction arm

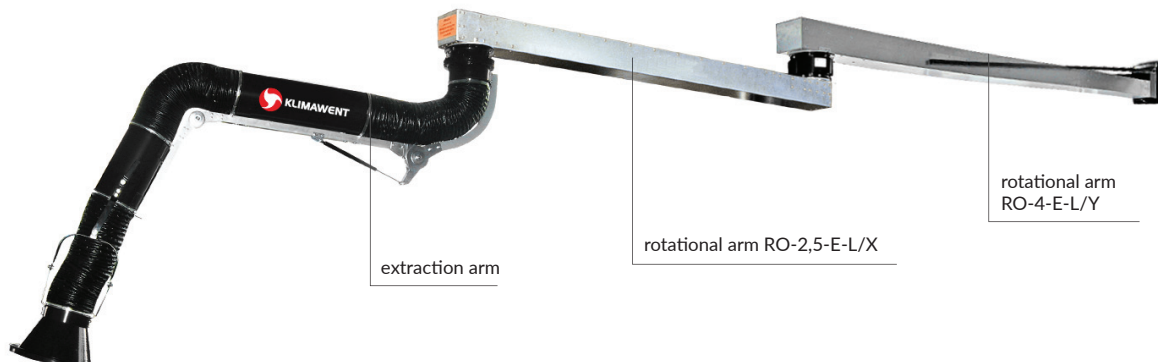

Rotational arm RO-E-L/X

Rotational arm type RO-E-L/X is adapted to connect the ERGO LUX-L extraction arm at its free end. The rotational arm has to be mounted to the wall of the room by means of a WP-RO/L wall bracket, in case of RO-1,5 and RO-2,5 rotational arms or directly installed to the wall RO-4-E-L/X.

Rotational arm RO-1,5-E-L/X

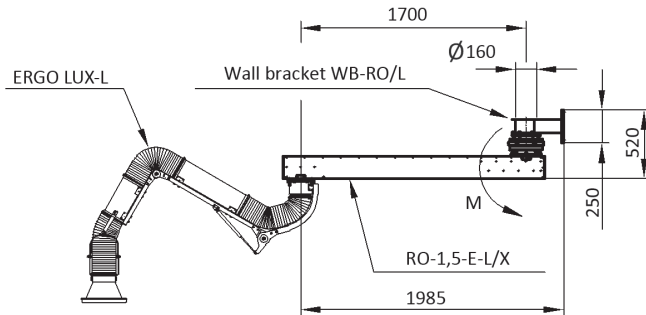

Rotational arm RO-2,5-E-L/X

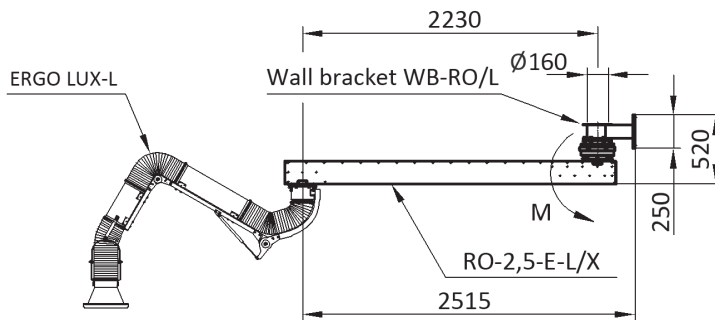

Rotational arm RO-4-E-L/X

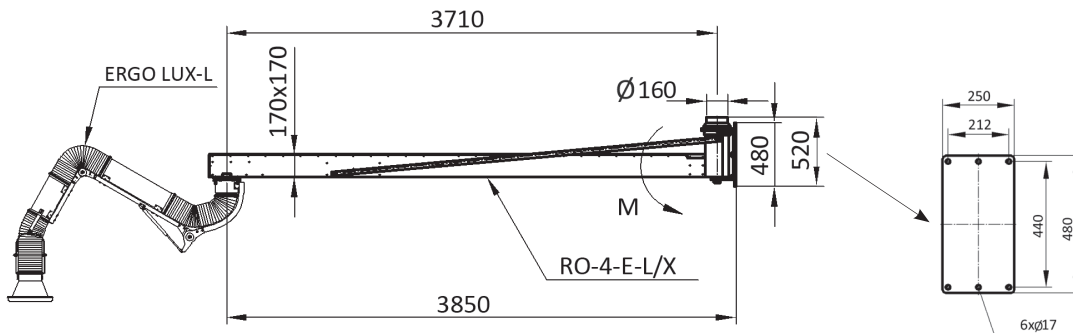

M - maximum torque applying load on the arm - see Table TECHNICAL DATA.

Rotational arm RO-E-L/Y

Rotational arm RO-E-L/Y – has been designed for connection the RO-1,5-E-L/X, RO-2,5-E-L/X rotational arm and simultaneously the ERGO LUX-L extraction arm. The rotational arm has to be mounted directly to the wall.

Rotational arm RO-2,5-E-L/Y

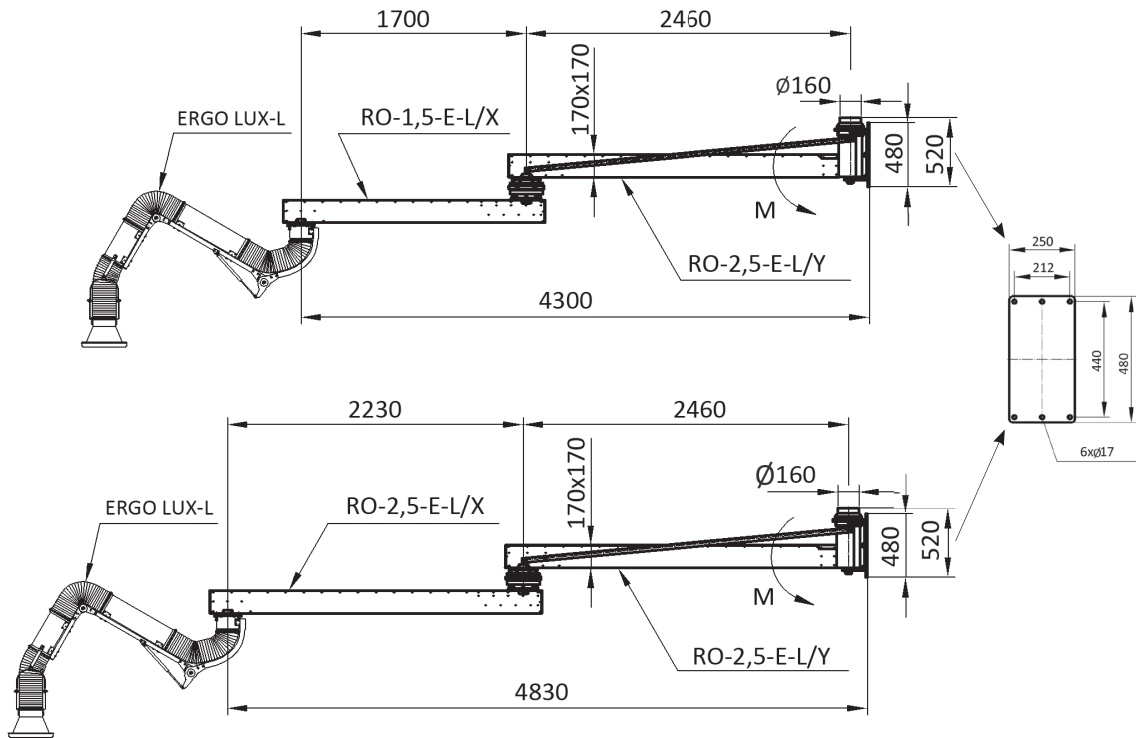

Rotational arm RO-4-E-L/Y

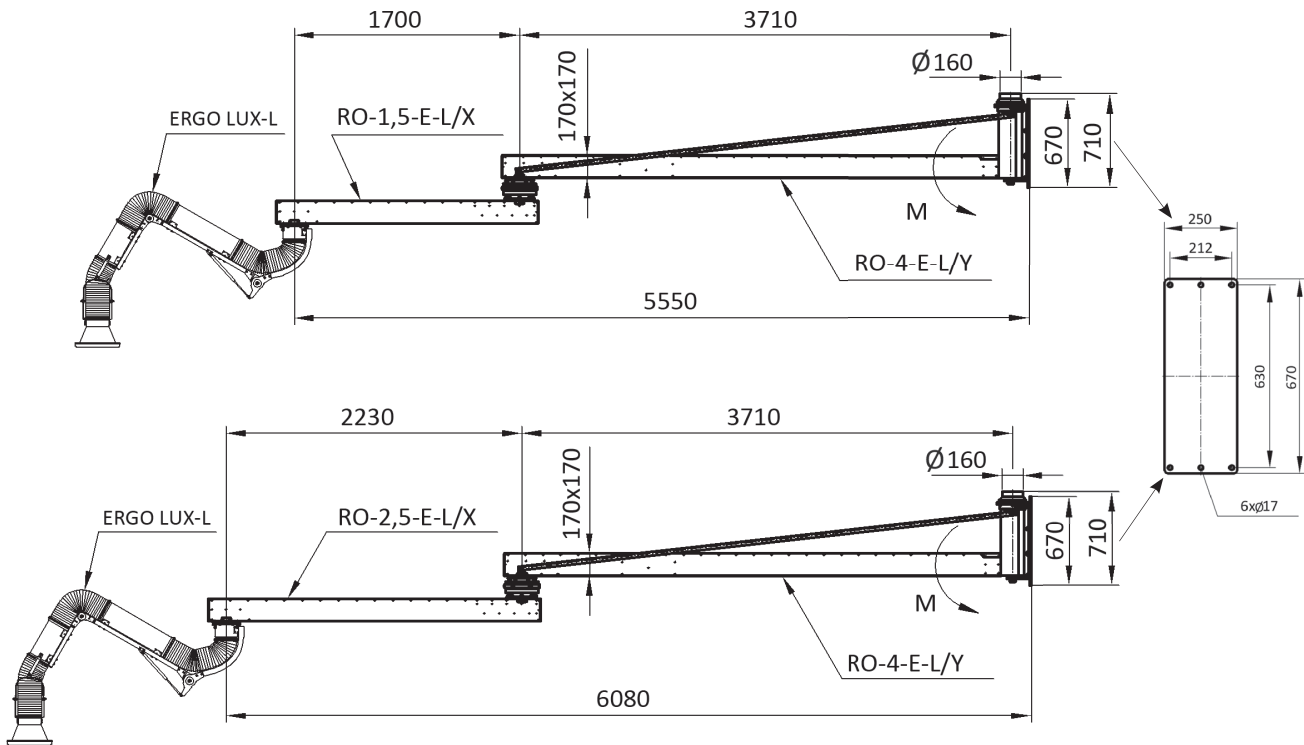

The WB-RO/L bracket serves to install the rotational arms – RO-1,5-E-L/X, RO-2,5-E-L/X. Wall bracket does not constitute standard equipment of the rotational arm – it has to be ordered separately.

Arms RO-4-E-L/X, RO-2,5-E-L/Y, RO-4-E-L/Y – are not equipped with a flange to install a fan.

M – maximum torque applying load on the arm – see Table TECHNICAL DATA.

Technical data

Type	Part no.	Connection diameter [mm]	Weight [kg]	Maximum torque M [Nm]
RO-1,5-E-L/X	811R16	160	46	1400
RO-2,5-E-L/X	811R17	160	51	1700
RO-4-E-L/X	811R22	160	84	3100
RO-2,5-E-L/Y	811R21	160	68	4400
RO-4-E-L/Y	811R23	160	98	6400

NOTE: Before installing the rotational arm, check if the load capacity of the wall (or other constructional element of the building) is sufficient to transmit the moment M, and it is also important to select the mounting bolts adequately.

Flow charts of the RO rotational arms

