

Use and Maintenance Manual



Separator **SEP-UFO-A-20000**

Contents:

1.	Introductory Remarks	3
2.	Application	3
3.	Reservations of Producer	4
4.	Technical Data	4
5.	Structure and Function	7
6.	Assembly and Start-up	7
7.	Operational Use	7
8.	Troubleshooting Guide	7
9.	Maintenance and control	7
10.	Occupational Health and Safety	8
11.	Transport and Storage	8
12.	Terms of warranty	8
13.	Sample of Declaration of Conformity	9

1. Introductory Remarks

The purpose of the present User's Manual is to supply User with directions within the range of application, installation, start-up and the operational use of the **SEP-UFO-A-20000 separator**.

Installing, start up and operational use are exclusively admissible after getting acquainted with the contents of the Use and Maintenance Manual.

With regard to continuity of work carried on improvement of our products, we reserve for ourselves the revision possibility of the draft and technological changes improving their functional features and safety.

The construction of the **SEP-UFO-A-20000 separator** meets the requirements of the current state of technology as well as the safety and health assurances included in:

- **2006/42/EC Machinery Directive** of the European Parliament and of the Council of 17 May, 2006 on machinery – amending the 95/16/EC (recast) /*Journal of Laws EC L157 of 09.06.2006, page 24*/

The device has been constructed and produced on the basis of following harmonized standards:

- **PN-EN ISO 12100:2012** – “Safety of machinery. Basic concepts, general principles for design. Risk assessment and risk reduction”.
-

2. Application

Generally, **SEP-UFO-A-20000 separators** serve as pre-filters, that capture dry and coarse dust, particles arising during various technological processes.

Additionally, separators are applied for:

- spark neutralising – during some processes – e.g. welding and grinding of metals,
- capturing of various sorts of harmful waste materials, e.g. not extinguished cigarettebutts, embers that would enter the discharge ducting, and subsequently into the final filter – during the use of a careless operator.

Due to their above mentioned features, separators protect the final filters from excessive dustiness overload and from possible fire risk.

SEP-UFO-A-20000 separators can work with any chosen final filters of approximately similar volume flow, especially with filtering units **UFO-A-20000**, as they are dimensionally suitable. Separators are not equipped with a fan. The air flow is created by the fan of the terminal filtering unit.

3. Reservations of Producer

- A. Manufacturer accepts no liability for any consequences following from the operational use that is in contradiction to the purpose of application.
- B. Installing of any additional elements not belonging to the normal device structure (or accessory set) is not acceptable.
- C. Any structural changes or modification of the separator, carried out by User on one's own are not permitted.
- D. Protect the housing from mechanical damage.
- E. Prior to installing, examine the load carrying capacity of the building structure, where the appliance will be mounted. Unsure mounting could cause hazard to personnel / people in the vicinity, as well as damage of the device itself.
- F. Do not apply the separator within the installation conveying the air polluted with a mixture of flammable substances (in form of gas, vapour and dust), that could create explosive atmosphere in combination with the air.
- G. Do not apply the separator for conveying the air containing viscous impurities that would build up within the device.
- H. The separator is not appropriate for forwarding the air with aggressive substances that would damage the device.

4. Technical Data

Table No.1

Parameters	Unit of measure	SEP-UFO-A-20000
Maximum air flow efficiency	[m ³ /h]	20000
Flow resistances (for efficiency as above)	[Pa]	200
Inlet diameter:	[mm]	630
Outlet diameter:	[mm]	500
Dimensions:		
Length:	[mm]	1235
Width:	[mm]	1235
Height:	[mm]	3360
Weight:	[kg]	375

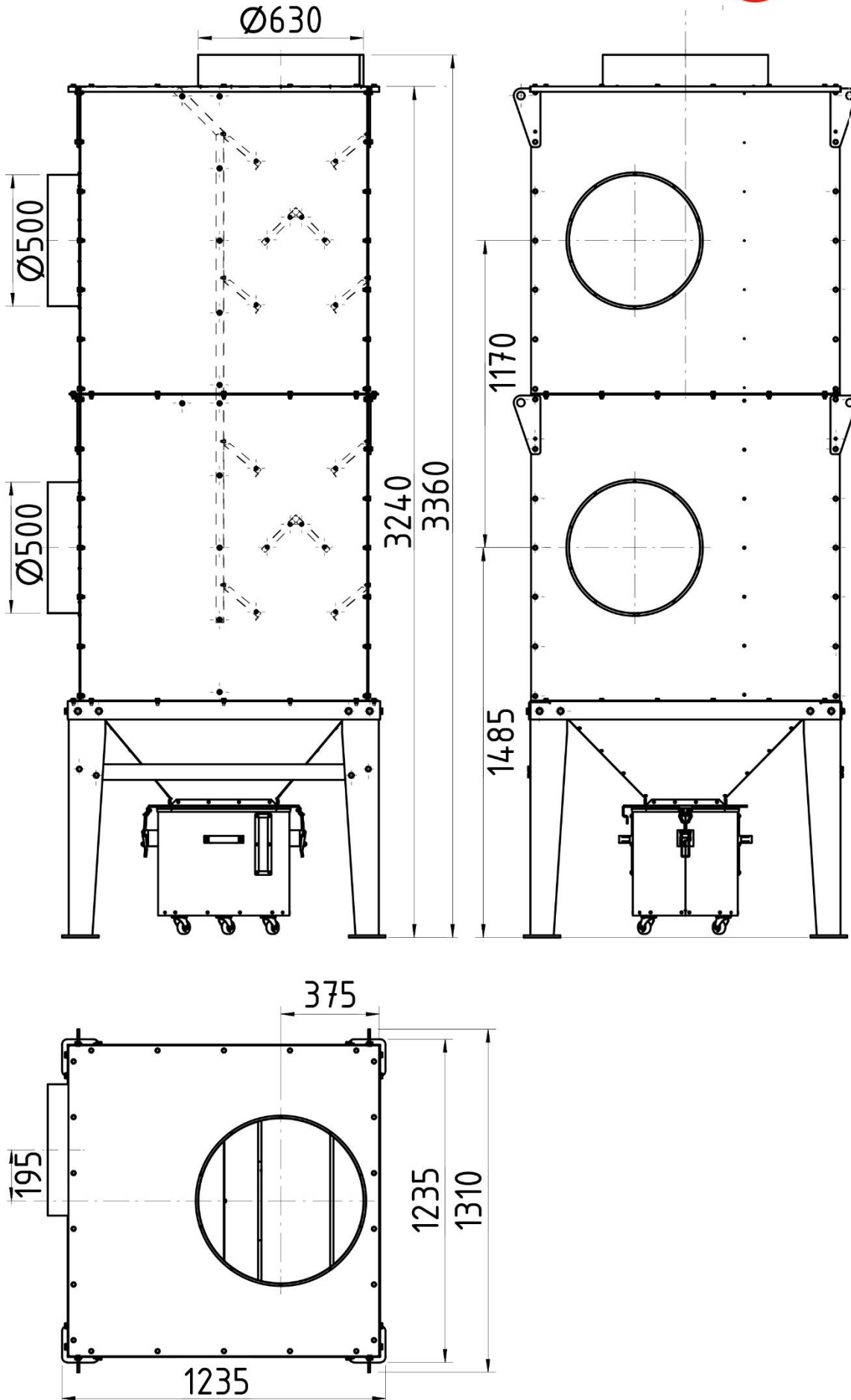

Fig. No. 1 – Structure and dimensions of the separator type SEP-UFO-A-20000 – left execution

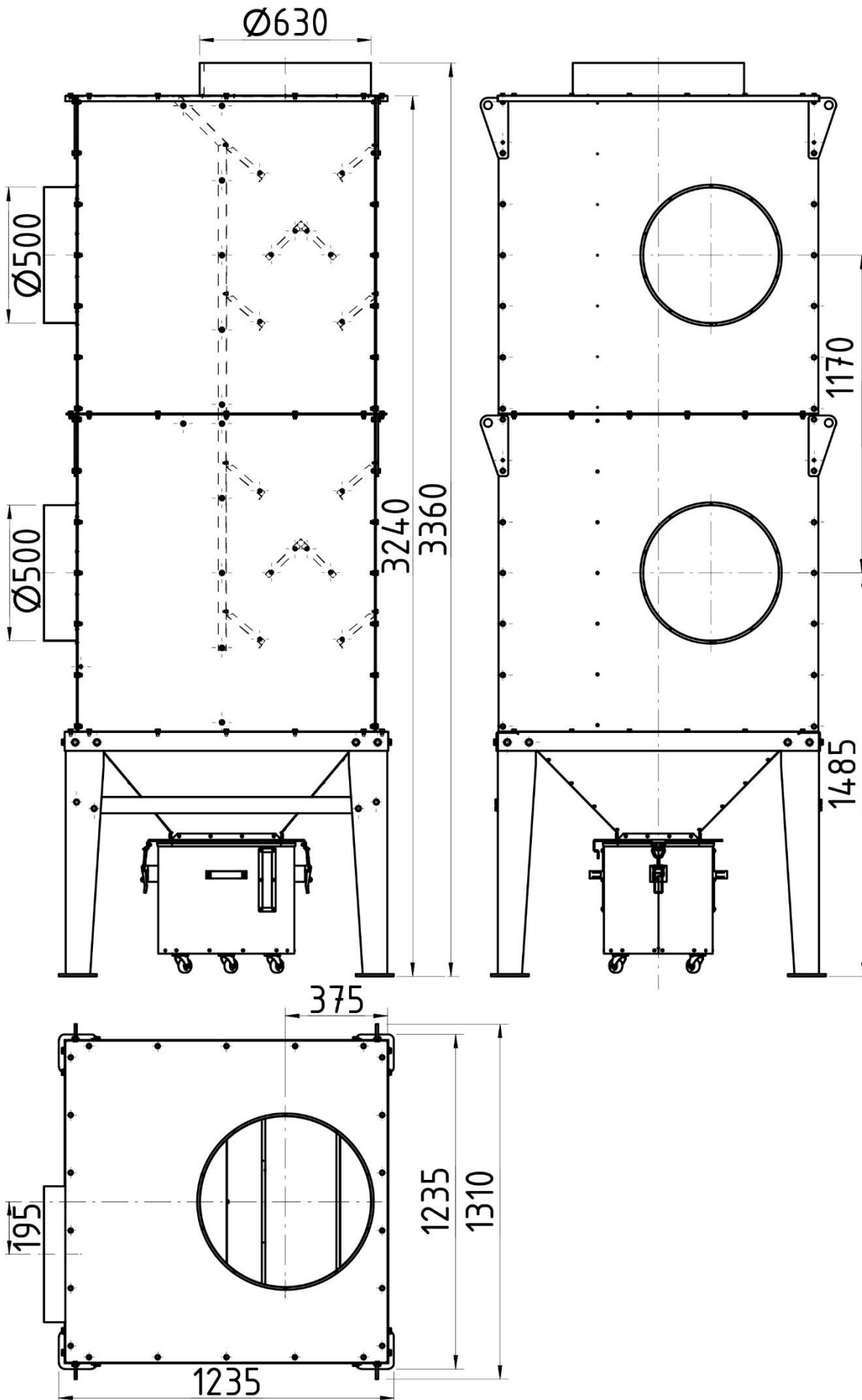

Fig. No. 2 – Structure and dimensions of the separator type SEP-UFO-A-20000 – right execution

5. Structure and Function

The separator consists of a separating chamber, placed on a four-leg base. Under the base there is a hopper connected with a waste container. The waste container is equipped with a sight-glass to control the fill-up state of the container.

Dust separation proceeds in an inertial process. The separated contaminants accumulate in the waste container which should be emptied periodically.

The appliance is equipped with an inlet and outlet fitting piece, that is connected with a filtering unit. Separators are not equipped with an individual fan. The air flow is created by the fan of the final filtering unit (UFO-A-20000).

6. Assembly and Start-up

SEP-UFO-A-20000 separator has been developed for application in closed rooms (indoor application). Simply, put it stably on the even floor surface. Whereby, important is the free access to the inspection openings and to the waste container. Prior to installing, check the load carrying capacity of the floor.

The appliance is delivered in assemblies. First install the base frame. On the frame put the separation chamber.

Before putting the chamber, seal up the contact surfaces between the base and chamber with silicon. The chamber is equipped with transport handles for easy manoeuvring/installing the chamber.

Having installed the separator, connect the waste container. The device ought to be connected to the grounding system.

7. Operational Use

The hopper discharge chamber directs the contaminants into the waste container which has to be emptied periodically. Prior to emptying, the hopper surfaces must be “tapped” to slide down the leftovers of the impurities.

8. Troubleshooting Guide

Table No.2

	Problem	Possible reason	Corrective action
1.	Increased acoustic pressure level during the function.	Leakage (untightness) of connections of installations or revision openings are protected inadequately	Examine the connections and the revision openings. Tighten up the connections and openings covers.

9. Maintenance and control

The appliance do not require everyday technical supervision, maintenance. It is sufficient to check the mechanical connections and the connection with the local equilibrating profile.

After a certain time, after the completed work, clean the separator chambers from the accumulated dust. Every time, before waste container emptying, the hopper chamber must be “tapped”.

10. Occupational Health and Safety

Prior to start and use, it is important to get acquainted with the present Use and Maintenance Manual.

WARNING Any work related to repair and technical revision ought to be carried out only after disconnection from the dust collecting ducting and from the power system.

11. Transport and Storage

SEP-UFO-A-20000 separator is transported in assemblies, packed in foil, placed on transport pallets. For the transport time the device assemblies should be placed in vertical position and protected from an uncontrolled overturn and displacement/slide.

As the device is a thin-wall construction, therefore safety measures are needed while lifting, transport, unloading, and installing of the subsequent assemblies.

The device has to be stored in a dry and well ventilated rooms.

12. Terms of warranty

The period of warranty for the purchased device is indicated in the “Card of Warranty”. The warranty does not comprise:

- mechanical damage and dysfunctions caused by User,
- device failures caused during use which was in contradiction with the purpose of operational use and the present Use and Maintenance Manual,
- damages being effected during improper transport, storage or incorrect maintenance.

Infringement of the Section 3 “Reservations of Producer” of the Use and Maintenance Manual and especially modifications undertaken by User on one’s own shall cause the loss of warranty validity.

13. Sample of Declaration of Conformity

Declaration of Conformity EC No.

Manufacturer (eventually the authorized representative / importer):

name: **KLIMAWENT S.A.**

address: **81-571 Gdynia, ul. Chwaszczyńska 194**

A person, authorized for issuing the technical documentation:

hereby declares that the appliance:

name: **Separator**

type/model: **SEP-UFO-A-20000**

serial number: year of production:

meets the requirements of the subsequent European Directives:

- **2006/42/EC Machinery Directive** of the European Parliament and of the Council of 17 May, 2006 on machinery – amending the 95/16/EC (recast) *Journal of Laws EC L157 of 09.06.2006, page 24*

The device has been constructed and produced on the basis of following harmonized standards:

- **PN-EN ISO 12100:2012** – “Safety of machinery. Basic concepts, general principles for design. Risk assessment and risk reduction”.

.....
place, date

KLIMAWENT S.A.

Supported Employment Enterprise

81-571 Gdynia, ul. Chwaszczyńska 194

phone: +49 58 829 64 80

email: klimawent@klimawent.com.pl

www.klimawent.com.pl

.....
signature of authorised person

District Court Gdańsk-Północ

in Gdańsk, VII Wydział Gospodarczy

of the National Register of Court

KRS 0000308902 company stock

13.779.200 zł paid in total

.....
name, surname, function
of the signatory

NIP: 958 159 21 35

REGON: 220631262

Bank Account: **Bank Zachodni WBK S.A.**

56 1500 1025 1210 2007 8845 0000

NOTES:

NOTES:



Producer:
KLIMAWENT S.A.
81-571 Gdynia, ul. Chwaszczyńska 194
tel. 058 629 64 80
fax 058 629 64 19
e-mail: klimawent@klimawent.com.pl
www.klimawent.com.pl

800S26 SEP-UFO-A-20000 21.11.2017/EN