



SMOKING BOX – cabin for smokers



Purpose

SMOKING BOX is a space in a form of a cabin for smokers, providing them hygienic conditions and comfort. Additionally, non-smoking people are protected from passive smoking working in the same room.

SMOKING BOX provides efficient protection of non-smoking people in companies, universities, hotels, gastronomic-entertainment premises, facilities for tourists and other spaces. Inside is sufficient space for 4 or 8 people. As the cabin is independent of the ventilation system of the building, it can stand in any optional place.

Structure

The cabin for smokers – SMOKING BOX consists of a glass cabin made of aluminium profiles. The walls and swinging door of toughened glass ensure safety, sufficient isolation from the surrounding and also gives aesthetic features. In the upper part of the SMOKING BOX is located a PD-1 smoke absorber with a very silent fan.

The PD-1 smoke absorber consists of:

- HEPA dust-stop high-efficiency filter – class H13 – capturing the tar substances at efficiency of 99,95%,

- filter of granulated active carbon – absorbing the noxious gaseous contaminations (nicotine, carbon monoxide, etc.).

The air is drawn into the SMOKING BOX through the slots between the structural elements. After filtering within the PD-1 filtration assembly (in the upper part) the air is expelled outside.

There are two device versions: SMOKING BOX and SMOKING BOX-2-DUAL, varying in size. The volume of the SMOKING BOX is 4 m³, and of SMOKING BOX-2-DUAL – 8 m³. The fan volume flow is 480 and 960 m³/h respectively, which provides 120 air changes an hour. SMOKING BOX-2-DUAL is equipped with two fans.

Inside the cabin is placed a self-extinguishing ashtray. The cabin is equipped with lighting in its ceiling – operated automatically by means of a motion sensor.

The cabin construction is dismantlable, therefore it is easy to transport and to displace it to another place of use.

Operational use

In the course of use, periodically replace the filters. Replacement time (in average conditions) is approx. 1 year.

Technical data

Type	Part no.	Volume flow [m ³ /h]	Supply voltage	Fan motor rate [W]	Acoustic pressure level [dB(A)] from a distance of 1 m:	Weight of the active carbon [kg]	Weight of the device [kg]
SMOKING BOX	800078	480	230 V/50 Hz	124	59	20	400
SMOKING BOX-2-DUAL	800069	960	230 V/50 Hz	248	59	40	710

1. On demand of Customer we offer annual service consisting in technical survey and replacement of the filters.

2. PD-1 smoke absorber carries HYGIENIC CERTIFICATE No. HK/B/0777/01/2013 issued by National Institute of Hygiene.

3. SMOKE ABSORBER meets the requirement of the regulation of health protection against the effects of smoking of cigarettes and tobacco products of 8th of April, 2010.

SMOKING BOX

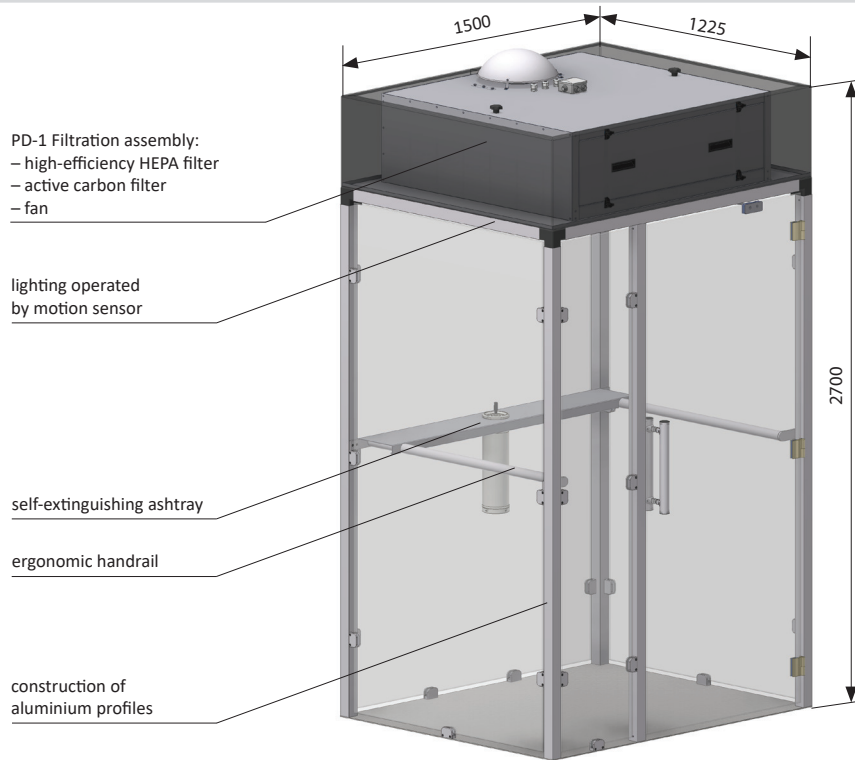

SMOKING BOX

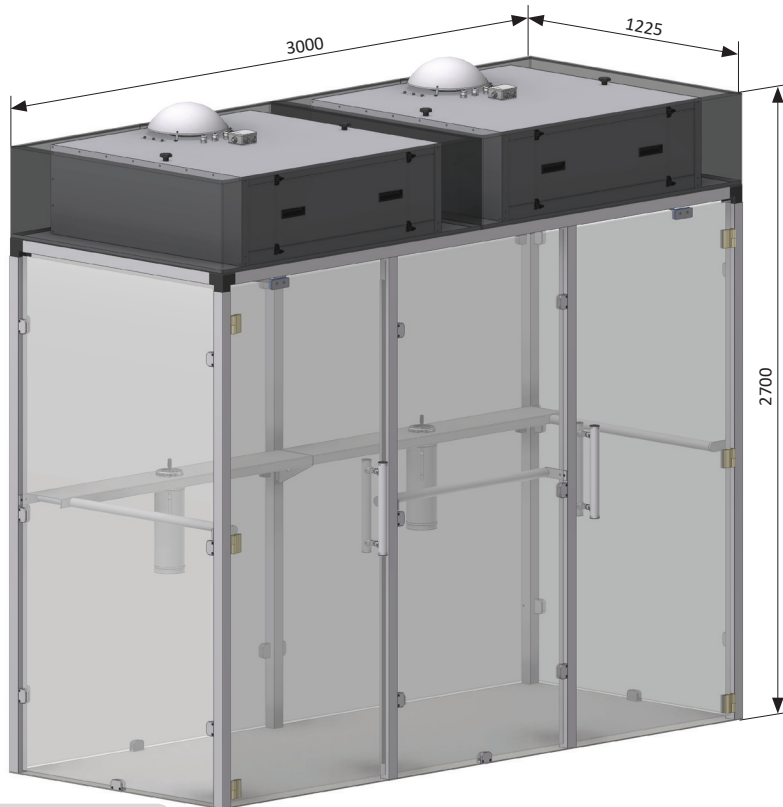

SMOKING BOX-2-DUAL

Replaceable parts

High-efficiency filter

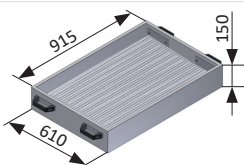

Type	Part no.	Filtration efficiency	Remarks
FA-SMOKING BOX	838F46	99,95%	Filter class – H13.

Carbon filter

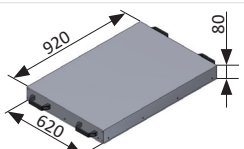

Type	Part no.	Weight of the active carbon [kg]
FW-SMOKING BOX	838F45	20